

INSULATED STAINLESS STEEL RADIANT HOT CABINET MODEL 1200HH2EE

FEATURES AND BENEFITS:

- Heated cabinet has two separate compartments and controls for flexibility in hot holding needs.
- Fully insulated cabinets keep prepared foods at serving temperatures.
- Powerful, yet efficient, 1800 Watt heating system maintains the right temperature to properly hold products. Heats up to 220°F. (104°C.).
- Standard solid state electronic controls with large, clear, easy-to-read and operate LED digital display to ensure holding at precise food temperature.
- Internal frame in body maintains structural rigidity.
- Safety-conscious anti-microbial latches protect against spreading germs.
- Stainless steel construction throughout for ease of cleaning.
- Insulated field reversible doors for flexibility. Standard with right hand hinging; left hand hinging available upon request.
- Magnetic latches for “easy open”; twist-lock catch secures doors during transport. Latches and hinges mounted inboard.
- Sixteen sets of chrome plated wire universal angles to accommodate a large variety of pan sizes on adjustable 1-1/2" centers.
- Heavy duty 5" casters, two swivel with brakes, two rigid. Provides mobility when fully loaded.



Standard solid state electronic controls with large, clear, easy-to-read and operate LED digital display to ensure holding at precise food temperature.

ACCESSORIES and OPTIONS (Available at extra cost):

- Key Lock Handles
- Corner Bumpers
- Perimeter Bumper
- Door Window
- Various Caster Options
- 240 Volt Service

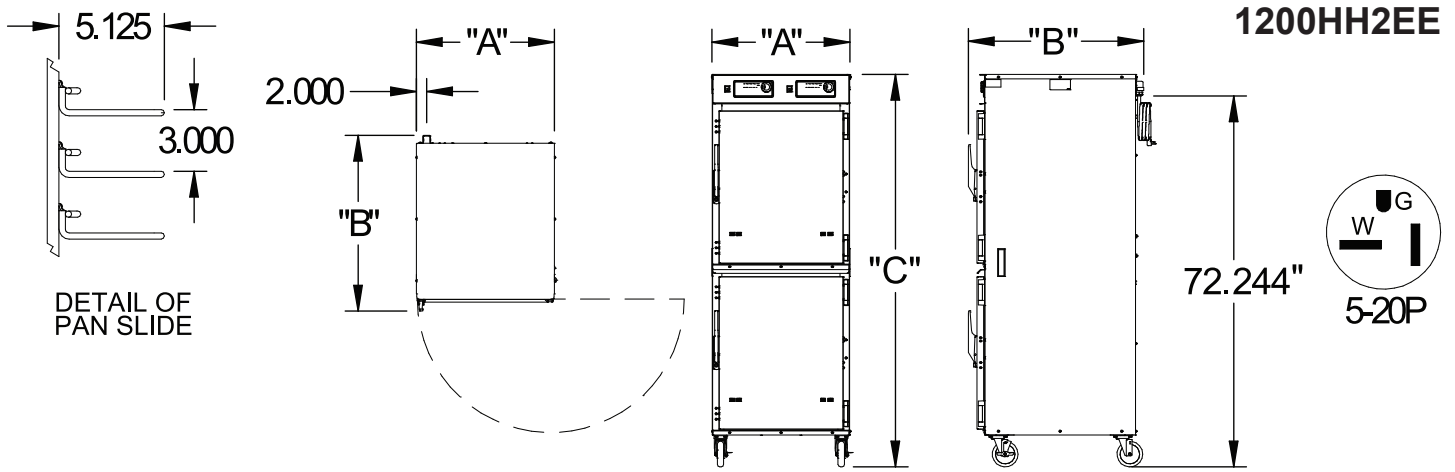

CRES COR MODEL NO.	PAN			DIM "A"	DIM "B"	DIM "C"	INSIDE DIMENSIONS				WEIGHT ACT.
	CAP	SIZE		WIDTH	DEPTH	HEIGHT	WIDTH	DEPTH	HEIGHT		
1200HH2EE	16	18 x 26	IN	26-7/8	34-1/8	76-3/8	23	27	28-3/4	LBS	345
		460 x 660	MM	682	867	1940	584	690	730	KG	157
	32	12 x 20	IN								
		305 x 510	MM								

When ordering bumpers, add 3-11/16 to DIM "A", 15/16 to DIM "B".

CABINETS:

- Bodies: 22 ga. outer and 20 ga. inner stainless steel compartments.
- Reinforcements: Internal framework of channels, 1 x 3/4 x .125.
- Insulation: Fiberglass, thermal conductivity (K factor) is .23 BTU/ft HR °F (.04 w/mK) at 75°F. 1-1/2" in top, bottom and walls, 1" in doors.

BASE:

- One piece construction, .060 stainless steel.
- Casters: 5" dia. swivel, modulus tires, 1-1/4" wide, load cap. 250 lbs. each, temp. range -45°/+180°F, Delrin bearings. Front casters equipped with brakes.

DOORS:

- Field reversible.
- Formed 20 ga. stainless steel.
- Latches: Chrome plated zinc with composite handle, magnetic type; mounted inboard.
- Transport knob.
- Hinges: Heavy duty chrome plated zinc; mounted inboard.
- Gaskets: Perimeter type, silicone.
- Vents: Adjustable.

PAN SLIDES:

- Wire angles (.306 dia.), nickel chrome plated steel, mounted on lift-off posts.
- Adjustable on 1-1/2" centers.

HOT UNIT COMPONENTS:

- Thermostats: Solid state digital display control, room ambient to 220°F (104°C).
- Switches: ON-OFF rocker type (2).
- Solid-state relays (2).
- Power cord: Permanent, 10 ft., 12/3 ga. with right angle plug.
- Heaters(6): 300 Watts each.

POWER REQUIREMENTS:

- 1800 Watts, 120 Volts, 60 Hz., single phase, 15 Amps., 20 Amp. service.

SHORT FORM SPECIFICATIONS

Cres Cor Insulated Hot Stainless Steel Cabinet Model 1200HH2EE. Outer liner of 22 ga., stainless steel, inner liner of 20 ga. stainless steel, reinforced with channel frame. Fiberglass insulation in walls 1-1/2"; door, top and bottom 1". Welded and finished. (6) 300 Watt inner wall heaters, 120 volts. (16) sets of wire universal angles for (16) 18" x 26" pans or (32) 12" x 20" pans; adjustable on 1-1/2" centers. 5" modulus casters, (2) swivel, (2) rigid. Delrin bearings. Load capacity 250 lbs. each. 2-Year Parts / 1-Year Labor warranty. Provide the following accessories: _____ CSA-US, CSA-C, CSA to NSF4 listed.



5925 Heisley Road • Mentor, OH 44060-1833
Phone: 877/CRESCOR • Fax: 440/350-7267
www.crescor.com

© Crescent Metal Products, Inc. 2026 All rights reserved.

In line with its policy to continually improve its products, CRES COR reserves the right to change materials and specifications without notice.

Made in America Since 1936