



QUIK THERM™ COOK AND HOLD STACKED CONVECTION OVEN MODEL: RO151XWUA5DXSTK

FEATURES AND BENEFITS:

for each compartment

- Air Fry, Bake, Cook, Roast, Rethermalize and even Hold with precise temperature and humidity control. Power boosting switch allows end user flexibility to increase or reduce air flow.
- Non-venting oven which passes the UL grease laden emission test permitted by most local codes, provides easy, inexpensive installation.
- Full 4700 Watts of power allows for reheating of prepared meals or bulk items. Maximum temperature 350°F. (176.5°C.).
- 1850 Watt water heater with separate control and low water indicator.
- Pre-setting automatic controls for roasting and holding cycles allows for unattended operation 24 hours a day.
- Operate all fans on high for air frying crispy foods.
- Standard solid state electronic control with large, clean, easy-to-read and operate LED digital display to ensure holding at precise food temperatures and moisture content.
- Non-venting oven, permitted by most local codes, provides easy, inexpensive installation.
- Stainless steel construction throughout for ease of cleaning.
- Smooth interior coved corners for ease of cleaning food particle/grease buildup.
- Field reversible insulated door. Silicone door gasket for proper seal prevents temperature loss. High temperature ceramic magnetic latch for “easy open” and security during transport. Two adjustable vents on each door.
- Safety-conscious anti-microbial latch protects against spreading germs. Standard with right hand hinging; left hand hinging available upon request.
- Non-corrosive stainless steel wire universal angles accommodate a large variety of pan sizes on adjustable 1-1/2" spacing. Supplied with five sets of angles.
- Safety-conscious water pan design drains to the rear.
- Heavy duty 5" swivel casters, two swivel brakes. (Provides mobility when fully loaded.)



RO151XWUA5DXSTK
(Shown with optional windows)

Deluxe (-DX)



Deluxe Controls are available with 18 programmable menus and 6" meat probe.

CUSTOM MODIFICATIONS

- Key Lock Latches
- Extra Universal Angles
- Side and Rear Bumpers



5925 Heisley Road • Mentor, OH 44060-1833
Phone: 877/CRESCOR • Fax: 440/350-7267
www.crescor.com

FEB. 2026

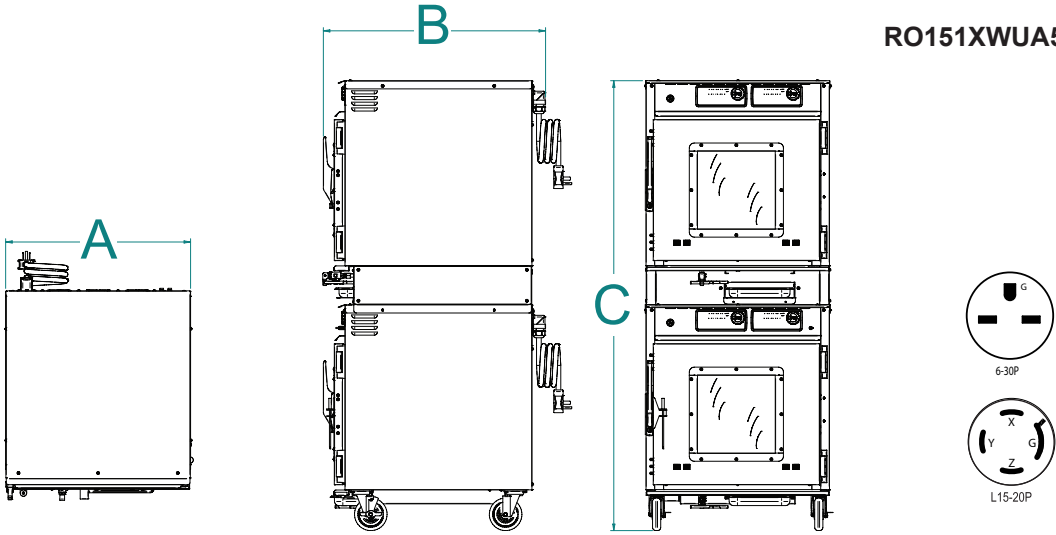

CRES COR MODEL NO.	PAN			DIM "A"	DIM "B"	DIM "C"	INSIDE DIMENSIONS				WEIGHT ACT.
	ANGLES	SIZE		WIDTH	DEPTH	HEIGHT	WIDTH	DEPTH	HEIGHT		
RO151XWUA5DXSTK	10 SETS	SEE NOTE BELOW	IN	28-1/8	35-1/8	69	22	26-1/2	20	LBS	475
			MM	720	890	1750	560	675	510	KG	215

Note: Refer to pan size chart at end of section.

CABINET:

- Body: 22 ga. stainless steel.
- Reinforcement: Internal framework of 16 ga. stainless steel.
- Insulation: Fiberglass, thermal conductivity (K factor) is .23 at 75°F. 1-1/2" in back wall, door, base; 2" in side walls.
- Water pan: 4 Gallons; 16 ga. stainless steel with 1850 Watt heater and with petcock drain; mounted to base.
- Each oven's water pan drains to the back of the unit.
- Drip trough: Formed 18 ga. stainless steel; mounted to lower front of cabinet; removable drip pan.
- Air tunnel: 20 ga. stainless steel, lift-out type, mounted on rear wall.

DOOR:

- Field reversible.
- Formed 22 ga. stainless steel.
- Latch: Anti-microbial chrome plated zinc with composite handle, ceramic magnetic type; mounted inboard.
- Hinges: Heavy duty chrome plated zinc, mounted inboard.
- Gasket: Perimeter type, silicone.
- Pan stop: Embossed.
- Adjustable vents, 2 on each door.

PAN SLIDES:

- Stainless steel wire universal angles (.306 dia.) mounted on lift-out posts.
- (5) sets of angles adjustable on 1-1/2" centers.

POWER REQUIREMENTS AVAILABLE:

- 4700 Watts, 208 Volts, 60Hz, 1 Phase, 22.5 Amps, 30 Amp Service
- 4700 Watts, 208 Volts, 60Hz, 3 Phase, 13 Amps, 20 Amp Service
- 4700 Watts, 240 Volts, 60Hz, 1 Phase, 20 Amps, 30 Amp Service
- 4700 Watts, 240 Volts, 60Hz, 3 Phase, 11.5 Amps, 20 Amp Service

POWER UNIT COMPONENTS: (each compartment)

- Thermostat (roast/hold): Solid state digital control, 140°F to 350°F (176.5°C).
- Thermostat (humidity): Solid state digital control, room ambient to 95%.
- Switch: ON-OFF push button type.
- Thermometer: Digital.
- Power cord: Permanent, 6 ft.; - Straight Blade Plug for 30 Amp. 6-30P
- Air heaters (6): 735 Watts each.
- Water heater: 1850 Watts.
- Blower motors (6).
- Vent fans (3).
- Fuses (2): 6 amp.

INSTALLATION REQUIREMENTS:

- This model complies with section 59 of UL710B for emissions of grease laden air, and according to UL is not required to be placed under a ventilation hood. Check local requirements before installation.



Scan QR code to view Spec Sheet, Operating Manual, Wiring Diagram or to call Cres Cor® Customer Service.

If you need a QR reader, visit your App Store on your device, or use the camera on your Smartphone.



5925 Heisley Road • Mentor, OH 44060-1833
 Phone: 877/CRESCOR • Fax: 440/350-7267
 www.crescor.com

© Crescent Metal Products, Inc. 2026 All rights reserved.

SHORT FORM SPECIFICATIONS

Cres Cor QuikTherm™ Cook and Hold Stacked Convection Oven Model RO151XWUA5DXSTK. 18ga. stainless steel, recessed control panel with digital thermostats. Cabinet 22 ga. stainless steel. Stainless steel internal frame; coved corner interior. 16 ga. stainless steel water reservoir, 4 gallon capacity. Fiberglass insulation in sides 2"; back, door and base 1-1/2". 22 ga. stainless steel door, high temperature anti-microbial magnetic latch, heavy duty hinges. (5) sets universal angles for multiple pan sizes and spacing. Heavy duty 5" swivel casters, two swivel brakes (for bottom compartment only). Delrin bearings. Load capacity 250 lbs. each. 4700 Watts, 208 Volts, 60 Hz., 1 Phase. 2-Year Parts / 1-Year Labor warranty. Provide the following accessories: _____ . CSA-US, CSA-C, CSA to NSF4 listed.

In line with its policy to continually improve its products, CRES COR reserves the right to change materials and specifications without notice.

Made in America Since 1936