

# QUIK THERM™ COOK AND HOLD CONVECTION OVEN

## MODEL: RO151XWUA5D SERIES

### FEATURES AND BENEFITS:

- Air Fry, Bake, Cook, Roast, Rethermalize and even Hold with precise temperature and humidity control. Power boosting switch allows end user flexibility to increase or reduce air flow.
- Non-venting oven which passes the UL grease laden emission test permitted by most local codes, provides easy, inexpensive installation.
- Full 4,700 Watts of power allows for cooking holding and rethermalizing of both scratch cooking or prepared bulk meals. Maximum temperature 350°F.
- Moist heat, dry heat or a combination of both allows for a variety of food preparation and holding.
- Operate all fans on high for air frying crispy foods.
- 1850 Watt water heater with separate control and low water indicator.
- Standard with automatic water fill system and low water indicator. LED and water heater shut off when water is at critically low level.
- Standard solid state electronic control with large, clean, easy-to-read and operate LED digital display to ensure holding at precise food temperatures and moisture content.
- AquaTemp system maintains optimum food texture through continuous monitoring of both temperature and humidity. Temperature and humidity values are measured, displayed and controlled through intuitive solid state controller. Air temperature is prioritized over humidity to ensure food safety.
- Stainless steel construction and smooth interior covered corners for ease of cleaning and to prevent food particle/grease buildup.
- Field reversible insulated door prevents temperature loss. Silicone door gaskets for proper seal. High temperature ceramic magnetic latches for "easy open" and security during transport. Two adjustable vents in each door.
- Safety conscious anti-microbial latches protect against spreading germs. Standard with right hand hinging; left hand hinging available upon request.
- Non-corrosive stainless steel wire universal angles accommodate a large variety of pan sizes on adjustable 1-1/2" spacing. Supplied with 5 sets of angles.
- Integral drip trough on front keeps traffic area dry, safer.
- Heavy duty 2-1/2" swivel casters, two with brakes. Provides mobility when fully loaded.



RO151XWUA5DX  
(shown with optional window and stand)

#### Standard (-DE)



All Ovens come standard with easy-to-read and operate LED digital controls.

#### Deluxe (-DX)



Deluxe Controls are available with 18 programmable menus and 3" meat probe.

### ACCESSORIES and OPTIONS

(Available at extra cost):

- Window
- Stand
- Security Panel for Controls
- Key Lock Latches
- Extra Universal Angles
- Side and Rear Bumpers

### POWER UNIT OPTIONS:

4700 Watts, 208 Volts, 1 or 3 Phase, 60 Hz.  
4700 Watts, 240 Volts, 1 or 3 Phase, 60 Hz.

**Deluxe Models (-DX) have 18 factory or field programmed cook & hold cycles. Each programmed menu can be customized for exact time and temperature needs. Probe cooking includes one 3" food temperature probe and port.**

# RO151XWUA5D

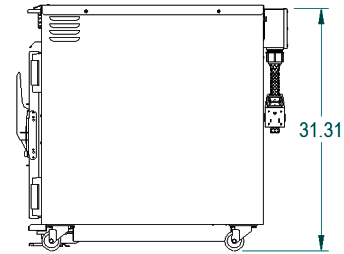
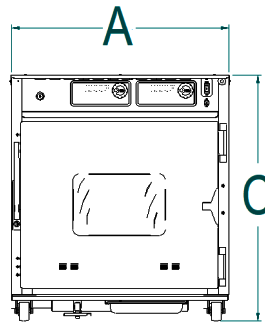
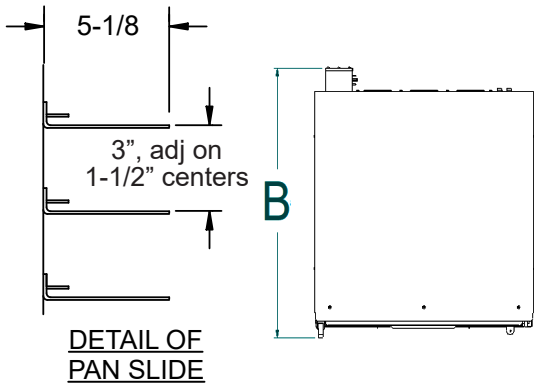

CRES COR MODEL NO.	PAN			DIM "A"	DIM "B"	DIM "C"	INSIDE DIMENSIONS				WEIGHT ACT.
	CAP/ANGLES	SIZE		WIDTH	DEPTH	HEIGHT	WIDTH	DEPTH	HEIGHT		
RO151XWUA5D	5 SETS	SEE NOTE BELOW	IN	28-1/8"	34"	31-3/4"	21-1/4"	26-1/2"	19-1/2"	LBS	260
			MM	714	863	806.45	539.75	673	495	KG	118

(-DE) models are standard models, (-DX) are upgraded deluxe models. See accessory sheet E-10 for more information.

NOTES: 1. Pan sizes 22" x 20" (560 x 510) Roast & Bake Pans, 10" x 20" (255 x 510) Roast & Bake Pans, 18" x 26" (460 x 660) Bun Pans, 14" x 18" (355 x 460) Service Trays, 12" x 20" (305 x 510) Steam Table Pans. Refer to Pan Size Chart at end of section.

2. When ordering bumpers, add 2" to overall dimensions.

## CABINET:

- Body: 22 ga. stainless steel.
- Reinforcement: Internal framework of 18 ga. stainless steel.
- Insulation: Fiberglass, thermal conductivity (K factor) is .23 at 75°F. 1-1/2" in doors, top, base; 2" in sidewalls.
- Air tunnels: 22 ga. stainless steel; lift-out type, mounted on sides.
- Water pan: 4 gallons; 16 ga. stainless steel with 1850 Watt heater for humidity.
- Automatic water fill hook-up under base, side.
- Interior coved corners

## BASE:

- One piece construction, .16 ga. stainless steel
- Drip trough: Formed 18 ga. stainless steel mounted to front of cabinet; removable drip pan.
- Casters: 2-1/2" dia., swivel, modulus tires, 1-1/4 wide, load cap. 150 lbs. each, temp. range -45°/+180°F. Delrin bearings. Front casters equipped with brakes.

## DOOR:

- Field reversible.
- Formed 22 ga. stainless steel.
- Latches: Chrome plated steel, high temperature ceramic magnetic type.
- Hinges: Heavy duty chrome plated steel.
- Gaskets: Perimeter type, silicone.
- Pan stops: Embossed.
- Adjustable vents.

## POWER REQUIREMENTS AVAILABLE:

- 4700 Watts, 208 Volts, 60 Hz., 1 Phase, 50 Amp. service.
- 4700 Watts, 208 Volts, 60 Hz., 3 Phase, 30 Amp. service.
- 4700 Watts, 240 Volts, 60 Hz., 1 Phase, 50 Amp. service.
- 4700 Watts, 240 Volts, 60 Hz., 3 Phase, 30 Amp. service.



Scan QR code to view Spec Sheet, Operating Manual, Wiring Diagram or to call Cres Cor® Customer Service.

If you need a QR reader, visit your App Store on your device, or use the camera on your Smartphone.

## PAN SLIDES:

- Stainless steel wire universal angles (.306 dia.), mounted on lift-out posts.
- 5 sets of angles; adjustable on 1-1/2" centers.

## ELECTRICAL COMPONENTS:

- Thermostat (retherm/hold): Solid state digital control, 140°F to 350°F (176.5°C).
- Thermostat (humidity): Solid state digital control, room ambient to 95%.
- Switch: ON-OFF push button type.
- Power Cord: Permanent, 8 ft., with right angle straight blade plug for 50A/1Ph. with twist lock plug for 30A/3Ph.
- Heaters (6): 735 Watts each.
- Switch: (1) Air volume.
- Blower motors: (6).
- Vent fans: (3).
- Water heater: 1850 Watts.
- Fuses: (2) 6 Amp.

**INSTALLATION REQUIREMENTS:** This model complies with section 59 of UL710B for emissions of grease laden air, and according to UL is not required to be placed under a ventilation hood. Check local requirements before installation.

## SHORT FORM SPECIFICATIONS

Cres Cor QuikTherm™ Cook and Hold Convection Oven, Model RO151XWUA5D. 18 ga. stainless steel, recessed control panel with digital thermostat. Cabinet 22 ga. stainless steel. Stainless steel internal frame; coved corner interior. 16 ga. stainless steel 4 gallon water reservoir with automatic water fill hook-up. Fiberglass insulation in sides 2"; back, doors and base 1-1/2". 22 ga. stainless steel door, high temperature anti-microbial magnetic latches, heavy duty hinges. Switch: (1) Air volume; Blower motors: (6); (5) sets universal angles for multiple pan sizes and spacing. One piece base .125 aluminum. 2-1/2" swivel modulus casters, Delrin bearings. Load capacity 150 lbs. each. \_\_\_\_\_ Watts, \_\_\_\_\_ Volts, 60 Hz., \_\_\_\_ Phase. 2-Year Parts / 1-Year Labor warranty. Provide the following accessories: \_\_\_\_\_ . CSA-US, CSA-C, CSA to NSF4 listed.

**CRES COR**

5925 Heisley Road • Mentor, OH 44060-1833  
Phone: 877/CRESCOR • Fax: 440/350-7267  
www.crescor.com

© Crescent Metal Products, Inc. 2025 All rights reserved.

*In line with its policy to continually improve its products, CRES COR reserves the right to change materials and specifications without notice.*

Made in America Since 1936