

AQUATEMP™/ROAST-N-HOLD™ UNDERCOUNTER CONVECTION OVEN MODEL CO151XWUA5D

FEATURES AND BENEFITS:

- Roast, cook, bake, reheat and hold with precise temperature and humidity control. Slow convected air system promotes natural browning for flavor and seals in natural juices.
- Moist heat, dry heat or a combination of both allows for a variety of food preparation and holding.
- Full 2000 Watts of power allows for reheating of prepared meals or bulk items. Maximum temperature 350°F. (176.5°C.).
- 1850 Watt water heater with separate control and low water indicator.
- Energy Management Logic system electronically directs power to where it's needed most during different operating cycles.
- Pre-setting automatic controls for roasting and holding cycles allows for unattended operation 24 hours a day.
- Roast and hold over 100 lbs. (45.4 kg.) of meat in just 6 sq. ft. of floor space. Convenient undercounter height makes the most of valuable kitchen space.
- Non-venting oven, permitted by most local codes, provides easy, inexpensive installation.
- Stainless steel construction throughout for ease of cleaning.
- Smooth interior coved corners prevent food particle/grease buildup.
- Field reversible insulated door prevents temperature loss. Silicone door gasket for proper seal. High temperature ceramic magnetic latch for "easy open" and security during transport. Two adjustable vents on each door.
- Safety conscious anti-microbial latch protects against spreading germs. Standard with right hand hinging; left hand hinging available upon request.
- Non-corrosive stainless steel wire universal angles accommodate a large variety of pan sizes on adjustable 1-1/2" spacing. Supplied with five sets of angles and two raised wire grids.
- Heavy duty 2-1/2" swivel casters, two with brakes. (Provides mobility when fully loaded.)

Deluxe Models (-DX) have 18 factory or field programmed cook & hold cycles. Each programmed menu can be customized for exact time and temperature needs. Probe cooking includes one 6" meat temperature probe and port.



CO-151-XW-UA-5DE

Standard (-DE)



Deluxe (-DX)



All Ovens come standard with easy-to-read and operate LED digital controls.

Deluxe Controls are available with 18 programmable menus and 6" meat probe.

ACCESSORIES and OPTIONS (Available at extra cost):

- Deluxe version with 18 programmable menus and 6" meat probe (or optional 3" food probe).
- Security Panel for Controls
- Key Lock Latch
- Extra Universal Angles
- Extra Wire Grids
- Side and Rear Bumpers
- 4700 Watts, 208 Volt
- 4700 Watts, 240 Volt
- 3 Phase

See page E-10 for accessory details.

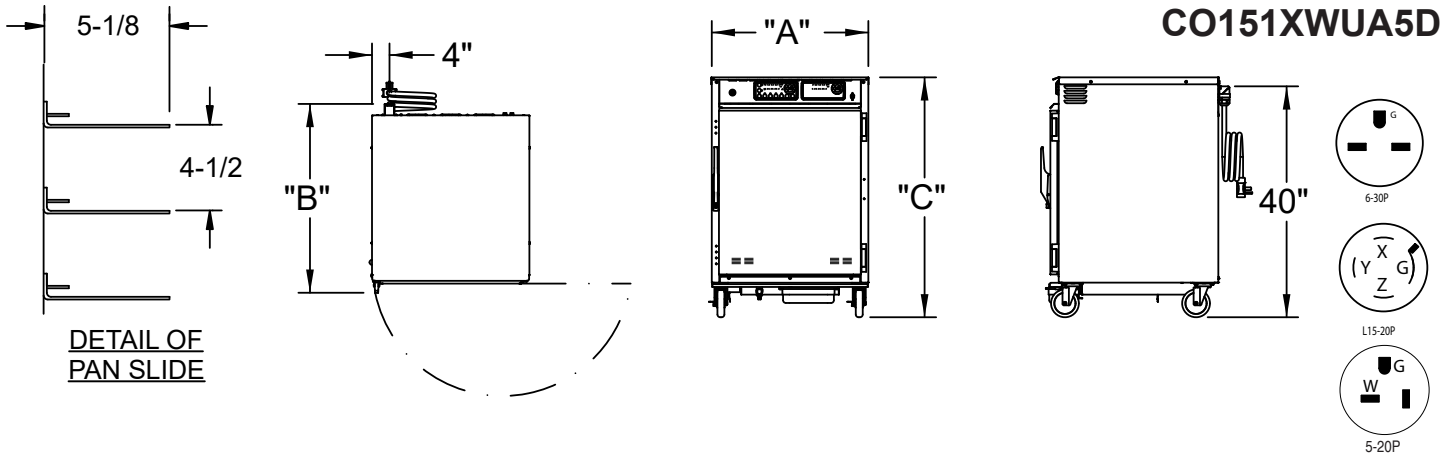

CRES COR MODEL NO.	PAN			DIM "A"	DIM "B"	DIM "C"	INSIDE DIMENSIONS			WEIGHT ACT.	
	ANGLES	SIZE		WIDTH	DEPTH	HEIGHT	WIDTH	DEPTH	HEIGHT		
CO151XWUA5DE	5 SETS	SEE NOTE BELOW	IN	28-1/4	34	32	21-1/4	26-1/2	20	LBS	200
CO151XWUA5DX			MM	718	864	815	540	675	510	KG	91

Note: Refer to pan size chart at end of section.

CABINET:

- Body: 22 ga. stainless steel.
- Reinforcement: Internal framework of 16 ga. stainless steel.
- Insulation: Fiberglass, thermal conductivity (K factor) is .23 at 75°F. 1-1/2" in back wall, door, base; 2" in side walls.
- Water pan: 4 Gallons; 16 ga. stainless steel with 1850 Watt heater and with petcock drain; mounted to base.
- Drip trough: Formed 18 ga. stainless steel; mounted to lower front of cabinet; removable drip pan.
- Air tunnel: 20 ga. stainless steel, lift-out type, mounted on rear wall.

BASE:

- One piece construction, .125 aluminum.
- Casters: 2-1/2" dia., swivel, polyolefin tires, 1-1/8 wide, load cap. 150 lbs. each, temp. range -40°/+180°F. Plain bearings. Front casters equipped with brakes.

DOOR:

- Field reversible.
- Formed 22 ga. stainless steel.
- Latch: Anti-microbial chrome plated zinc with composite handle, ceramic magnetic type; mounted inboard.
- Hinges: Heavy duty chrome plated zinc, mounted inboard.
- Gasket: Perimeter type, silicone.
- Pan stop: Embossed.
- Adjustable vents, 2 on each door.

PAN SLIDES:

- Stainless steel wire universal angles (.306 dia.) mounted on lift-out posts.
- (5) sets of angles adjustable on 1-1/2" centers.
- Grids (2): Nickel chrome plated steel, raised wire 17" x 25".



Scan QR code to view Spec Sheet, Operating Manual, Wiring Diagram or to call Cres Cor® Customer Service.

If you need a QR reader, visit your App Store on your Smartphone or Tablet.



5925 Heisley Road • Mentor, OH 44060-1833
 Phone: 877/CRESCOR • Fax: 440/350-7267
 www.crescor.com

© Crescent Metal Products, Inc. 2021 All rights reserved.

POWER REQUIREMENTS AVAILABLE:

- 2000 Watts, 120 Volts, 60 Hz., 1 phase, 16 Amps., 20 Amp. service.

POWER UNIT COMPONENTS: (refer to above drawing)

- Thermostat (roast/hold): Solid state digital control, 140°F to 350°F (176.5°C).
- Thermostat (humidity): Solid state digital control, room ambient to 95%.
- Switch: ON-OFF push button type.
- Thermometer: Digital.
- Power cord: Permanent, 6 ft.; - Straight Blade Plug for 20 Amp.
- Air heaters (2): 925 Watts each.
- Water heater: 1850 Watts.
- Blower motors (4).
- Vent fans (3).
- Fuses (2): 6 amp.

INSTALLATION REQUIREMENTS:

- This model complies with section 59 of UL710B for emissions of grease laden air, and according to UL is not required to be placed under a ventilation hood. Check local requirements before installation.

SHORT FORM SPECIFICATIONS

Cres Cor AquaTemp Roast-N-Hold Convection Oven Model CO151XWUA5D. 18 ga. stainless steel, recessed control panel with digital thermostats. Cabinet 22 ga. stainless steel. Stainless steel internal frame; coved corner interior. 16 ga. stainless steel water reservoir, 4 gallon capacity. Fiberglass insulation in sides 2"; back, door and base 1-1/2". 22 ga. stainless steel door, high temperature anti-microbial magnetic latch, heavy duty hinges. (5) sets universal angles for multiple pan sizes and spacing. One piece base .125 aluminum. 2-1/2" swivel modulus casters, Delrin bearings. Load capacity 150 lbs. each. 2000 Watts, _____ Volts, 60 Hz., _____ Phase. 2-Year Parts / 1-Year Labor warranty. Provide the following accessories: _____ . CSA-US, CSA-C, CSA to NSF4 listed.

In line with its policy to continually improve its products, CRES COR reserves the right to change materials and specifications without notice.

Litho in U.S.A.