

INSULATED STAINLESS STEEL RADIANT HOT CABINET MODEL 1000-HH-SS-SPLIT-DE

FEATURES AND BENEFITS:

- Fully insulated cabinets keep prepared foods at serving temperatures.
- Powerful, yet efficient, 900 Watt heating system maintains the right temperature to properly hold products. Heats up to 200°F. (93°C.).
- Simple LED electronic digital display to ensure holding at precise food temperature.
- Internal frame in body and doors maintains structural rigidity.
- Safety-conscious anti-microbial latches protect against spreading germs.
- Stainless steel construction throughout for ease of cleaning.
- Insulated field reversible doors for flexibility. Standard with right hand hinging; left hand hinging available upon request.
- Magnetic latches for “easy open”; twist-lock catch secures doors during transport. Latches and hinges mounted inboard.
- Wire pan supports are removable for easy cleaning and hold 18" x 26" and 12" x 20" pans on 2-3/4" centers.
- Heavy duty 5" swivel casters, two with brakes, that provide mobility when fully loaded.



1000-HH-SS-SPLIT-DE



Easy-to-operate electronic controls with LED digital display to ensure holding at precise food temperature.

ACCESSORIES and OPTIONS (Available at extra cost):

- Key Lock Handles
- Corner Bumpers
- Perimeter Bumper
- Door Window
- Various Caster Options
- 240 Volt Service
- Various Interior Rack Options

See page B-30 for accessory details.

1000-HH-SS-SPLIT-DE

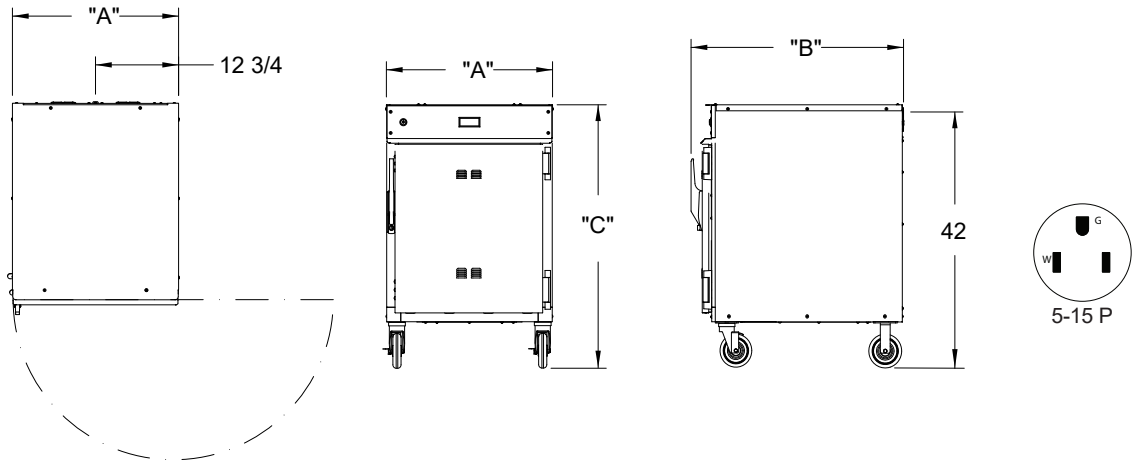

CRES COR MODEL NO.	PAN			DIM "A" WIDTH	DIM "B" DEPTH	DIM "C" HEIGHT	INSIDE DIMENSIONS			WEIGHT ACT.	
	CAP	SIZE					WIDTH	DEPTH	HEIGHT		
1000-HH-SS-SPLIT-DE	8	12 X 20	IN	22-5/8	32-3/4	42	18-3/16	27	25	LBS	215
		305 X 510	MM	575	831	1067	462	685	635	KG	98
	8	18 X 26	IN								
		460 X 660	MM								

When ordering bumpers, add 2" to overall dimensions.

CABINETS:

- Bodies: 22 ga. outer and 18 ga. inner stainless steel compartments.
- Reinforcements: Internal framework of channels, 1 x 3/4 x .125.
- Insulation: Fiberglass, thermal conductivity (K factor) is .23 BTU/ft HR °F (.04 w/mK) at 75°F. 1-1/2" in top, bottom and walls, 1" in doors.

BASE:

- One piece construction, .060 stainless steel.
- Casters: 5" dia. swivel, modulus tires, 1-1/4" wide, load cap. 250 lbs. each, temp. range -45°/+180°F, Delrin bearings. Front casters equipped with brakes.

DOORS:

- Field reversible.
- Formed 22 ga. stainless steel.
- Latches: Chrome plated zinc with composite handle, magnetic type; mounted inboard.
- Transport knob.
- Hinges: Heavy duty chrome plated zinc; mounted inboard.
- Gaskets: Perimeter type, silicone.
- Vents: Adjustable.

PAN SLIDES:

- Wire rack with .250 dia. wire vertically and .208 dia. wire horizontally. Nickel chrome plated steel spaced on 2-3/4" centers.



Scan QR code to view Spec Sheet, Operating Manual, Wiring Diagram or to call Customer Service.

If you need a QR reader visit your App Store on your Smartphone or Tablet.



5925 Heisley Road • Mentor, OH 44060-1833
Phone: 877/CRESCOR • Fax: 440/350-7267
www.crescor.com

© Crescent Metal Products, Inc. 2020 All rights reserved.

HOT UNIT COMPONENTS:

- Thermostats: Solid state digital display control, room ambient to 200°F (93°C).
- Switches: ON-OFF push button type.
- Power cord: Permanent, 6 ft., 14/3 ga. with right angle plug.
- Heaters(3): 300 Watts each.
- Vent fans.

POWER REQUIREMENTS:

- 900 Watts, 120 Volts, 60 Hz., single phase, 15 Amps., 15 Amp. service.

SHORT FORM SPECIFICATIONS

Cres Cor Insulated Hot Stainless Steel Cabinet Model 1000-HH-SS-SPLIT-DE. Outer liner of 22 ga., stainless steel, inner liner of 18 ga. stainless steel, reinforced with channel frame. 1-1/2" Fiberglass insulation in top, bottom and walls; 1" in door. Welded and finished. (3) 300 Watt inner wall heaters, 120 volts. Removable pan supports for 12" x 20" or 18" x 26" pans spaced on 2-3/4" centers. 5" swivel modulus casters, Delrin bearings. Load capacity 140 lbs. each. 2-Year Parts / 1-Year Labor warranty. Provide the following accessories: _____ CSA-US, CSA-C, CSA to NSF4 listed.

In line with its policy to continually improve its products, CRES COR reserves the right to change materials and specifications without notice.

Made in America Since 1936