

REThERM HEAT-N-HOLD™ OVEN MODEL RO-151-FUA-18B

FEATURES AND BENEFITS:

- Fully insulated Retherm Heat-N-Hold oven designed for both reconstituting precooked foods and slow roasting.
- Slow convected air system promotes natural browning for flavor and seals in natural juices.
- Full 8200 Watts of power allows for rethermalization of prepared meals or bulk items. Maximum temperature 350°F. (176.5°C.).
- Pre-setting automatic controls for rethermalizing and holding cycles allows for unattended operation 24 hours a day.
- Non-venting oven, permitted by most local codes, provides easy, inexpensive installation.
- Self-contained power top lifts off for ease of maintenance; available to suit your power requirements.
- Stainless steel construction throughout for ease of cleaning.
- Smooth interior coved corners prevent food particle/grease buildup.
- Field reversible insulated Dutch doors prevent temperature loss. Silicone door gaskets for proper seal. High temperature ceramic magnetic latches for “easy open” and security during transport.
- Safety conscious anti-microbial latches protect against spreading germs. Standard with right hand hinging; left hand hinging available upon request.
- Recessed push/pull handles on both sides prevent damage to walls; allows easy maneuvering.
- Chrome plated wire universal angles accommodate a large variety of pan sizes on adjustable 1-1/2" spacing. Supplied with 18 sets of angles.
- Heavy duty 5" swivel casters, two with brakes. Provides mobility when fully loaded.

POWER UNIT OPTIONS:

8200 Watts, 208 Volts, 1 Phase, 60 Hz.

8200 Watts, 240 Volts, 1 Phase, 60 Hz.

8200 Watts, 208 Volts, 3 Phase, 60 Hz.

8200 Watts, 240 Volts, 3 Phase, 60 Hz.

Probe Power Unit Available at Extra Cost (see page E-6)



RO-151-FUA-18B

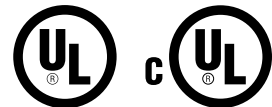

ACCESSORIES and OPTIONS (Available at extra cost):

- Security Panel for Controls
- Tempered Glass Door Windows
- Key Lock Latches
- Extra Wire Grids
- Extra Universal Angles
- Perimeter Bumper
- Corner Bumpers
- Floor Lock (for use with 5" casters)
- Various Caster Options

See page E-10 for accessory details.

RO-151-FUA-18B

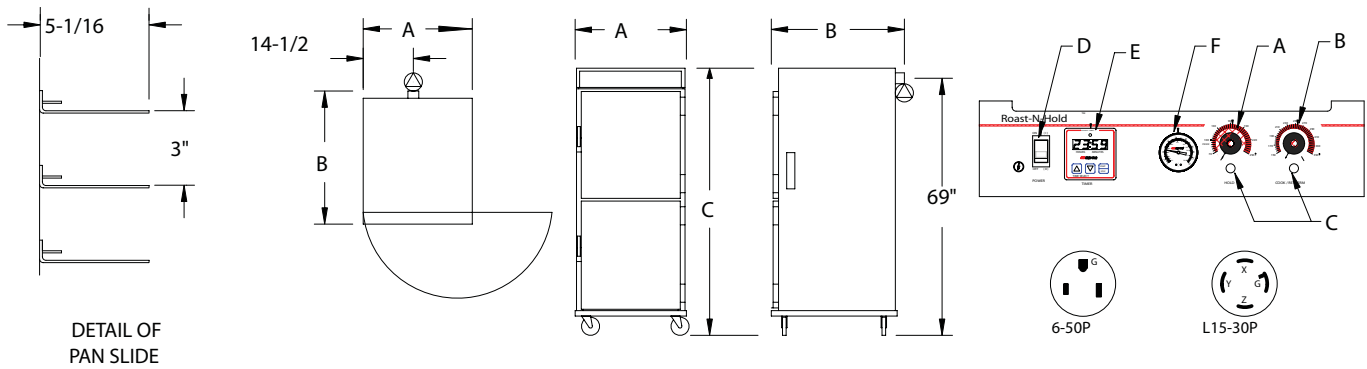

CRES COR MODEL NO.	PAN			DIM "A"	DIM "B"	DIM "C"	INSIDE DIMENSIONS				WEIGHT ACT.
	CAP/ANGLES	SIZE		WIDTH	DEPTH	HEIGHT	WIDTH	DEPTH	HEIGHT		
RO-151-FUA-18B	18 SETS	SEE NOTE BELOW	IN	28-3/4	37-3/4	73-1/2	21-1/4	26-1/2	58	LBS	390
			MM	730	960	1870	540	675	1475	KG	178

NOTE: Refer to Pan Size Chart at end of section.
ALL CONSTRUCTION IS RIVETED, WELDED AND FINISHED.

CABINET:

- Body: 22 ga. stainless steel.
- Reinforcement: Internal framework of 16 ga. stainless steel.
- Insulation: Fiberglass, thermal conductivity (K factor) is .23 at 75°F. 1-1/2" in back wall, doors, base; 2" in side walls.
- Air tunnel: 20 ga. stainless steel, lift-out type, mounted on rear wall.
- Push/pull handles (2): 7" vertical; recessed.

BASE:

- One piece construction, .125 aluminum.
- Casters: 5" dia., swivel, modulus tires, 1-1/4 wide, load cap. 250 lbs. each, temp. range -45/+180°F. Delrin bearings. Front casters equipped with brakes.

DUTCH DOORS:

- Field reversible.
- Formed 22 ga. stainless steel.
- Latches: Anti-microbial chrome plated zinc with composite handle, ceramic magnetic type; mounted inboard.
- Hinges: Heavy duty chrome plated zinc, lift-off type; mounted inboard.
- Gaskets: Perimeter type, silicone.
- Pan stops: Embossed.

PAN SLIDES:

- Wire angles (.306 dia.), nickel chrome plated steel; mounted on lift-out posts.
- 18 sets of angles adjustable on 1-1/2" centers.

POWER REQUIREMENTS AVAILABLE:

- 8200 Watts, 208 Volts, 60 Hz., 1 phase, 39 Amps., 50 Amp. service.
- 8200 Watts, 240 Volts, 60 Hz., 1 phase, 34 Amps., 50 Amp. service.
- 8200 Watts, 208 Volts, 60 Hz., 3 phase, 23 Amps., 30 Amp. service.
- 8200 Watts, 240 Volts, 60 Hz., 3 phase, 20 Amps., 30 Amp. service.

POWER UNIT COMPONENTS: (refer to above drawing)

- Body: Formed 20 ga. stainless steel with black control panel, recessed and tilted 7°.
- A) Thermostat (holding): Solid state, 140°F. (60°C.) to 250°F. (121°C.).
- B) Thermostat (cook/retherm): Solid state, 140°F. (60°C.) to 350°F. (176.5°C.).
- C) Pilot lights (2).
- D) Switch: Lighted ON-OFF rocker type.
- E) Timer: 24 hr. digital countdown; infinite memory retention.
- F) Thermometer.
- Power cord: Permanent, 6 ft., 6/3 ga. with right angle plug.
- Heaters (3): 2670 Watts each.
- Blower motors (3).
- Vent fans (2).
- Fuses (2): 3 Amp.

INSTALLATION REQUIREMENTS:

- Check local vent hood codes for mobile Roast-N-Hold ovens.

SHORT FORM SPECIFICATIONS

Cres Cor Retherm Heat-N-Hold Oven Model RO-151-FUA-18B. Removable power unit 20 ga. stainless steel, recessed control panel. Cabinet and Dutch doors 22 ga. stainless steel; stainless steel internal frame; coved corner interior. Fiberglass insulation in sides 2"; back, doors and base 1-1/2". High temperature anti-microbial magnetic latches. (18) sets universal angles for multiple pan sizes and spacing. One piece base .125 aluminum. 5" swivel modulus casters, Delrin bearings. Load capacity 250 lbs. each. 8200 Watts,
 _____ Volts, 60 Hz., _____ Phase. 2 year parts warranty. Provide the following accessories:
 _____ . UL Sanitation, UL, CUL listed.



5925 Heisley Road • Mentor, OH 44060-1833
 Phone: 877/CRESCOR • Fax: 440/350-7267
 www.crescor.com

© Crescent Metal Products, Inc. 2008 All rights reserved.

In line with its policy to continually improve its products, CRES COR reserves the right to change materials and specifications without notice.

Litho in U.S.A.