

## INSULATED CHILLTEMP® REFRIGERATED CABINET MODEL R-171-SUA-10

### FEATURES AND BENEFITS:

- Fully insulated mobile ChillTemp® refrigerated cabinet for holding food and beverages at serving temperature.
- Forced air system provides even distribution of cold air; cabinet maintains temperatures from 33°F (.5° C) to 40°F (4.5° C). Automatically defrosts.
- 1/3 horsepower compressor with automatic overload reset. R134a refrigerant for environmental compatibility.
- Stainless steel construction throughout for ease of cleaning. One piece extended base protects cabinet body.
- Recessed push/pull handles on both sides prevent damage to walls; allows easy maneuvering.
- Self-closing insulated door prevents temperature loss. Magnetic door gaskets for proper seal. Field reversible for flexibility.
- Standard with right hand hinging; left hand hinging available upon request.
- Safety-conscious anti-microbial handles protect against spreading germs.
- Full length extruded door handles for "easy open"; positive catch (available in USA only) secures door during transport.
- Generous 18-cubic foot interior.
- Ten sets of chrome plated wire universal angles accommodate a large variety of pan sizes on adjustable 1-1/2" centers.
- Heavy duty 5" swivel casters, two with brakes. Provides mobility when fully loaded.



R-171-SUA-10

(Shown with optional magnetic latch and perimeter bumper)

SANITATION  
NSF/ANSI 4

C US



ENERGY STAR

### ACCESSORIES and OPTIONS (Available at extra cost):

- Extra Universal Angles
  - Transport Angles
  - Menu Card Holder
  - Corner Bumpers
  - Perimeter Bumper
  - Floor Lock
  - Polyurethane Casters
  - Magnetic Door Latch (USA only)
  - 240 Volt Service
  - Digital Thermometer
  - Interior for (28) 18" x 26" pans
- See page K-2 for accessory details.

# R-171-SUA-10

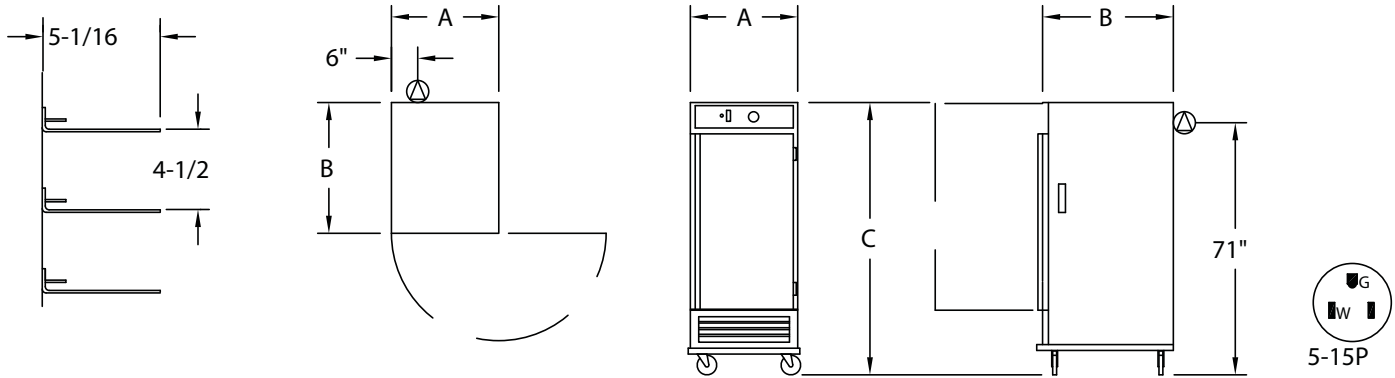

DETAIL OF  
PAN SLIDE

CRES COR MODEL NO.	PAN			DIM "A"	DIM "B"	DIM "C"	INSIDE DIMENSIONS			WEIGHT ACT.	
	CAP/ ANGLES	SIZE		WIDTH	DEPTH	HEIGHT	WIDTH	DEPTH	HEIGHT		
R-171-SUA-10	10 SETS	SEE NOTE BELOW	IN	28-3/4	34	73-3/8	22	27-1/2	46-3/4	LBS	350
			MM	730	865	1865	560	700	1190	KG	159

NOTES: 1. Pan sizes 22" x 20" (560 x 510) Roast & Bake Pans, 10" x 20" (255 x 510) Roast & Bake Pans, 18" x 26" (460 x 660) Bun Pans, 14" x 18" (355 x 460) Service Trays, 12" x 20" (305 x 510) Steam Table Pans.  
Refer to Pan Size Chart at end of section.

2. When ordering bumpers, add 2" to overall dimensions.

ALL CONSTRUCTION IS RIVETED, WELDED AND FINISHED.

## CABINET:

- Body: 22 ga. stainless steel.
- Reinforcement: Internal framework of 16 ga. stainless steel.
- Insulation: Fiberglass, thermal conductivity (K factor) is .23 at 75°F. 1-1/2" in doors, base, top; 2" in sidewalls.
- Push/pull handles (2): 5" vertical; recessed.
- Interior coved corners.

## BASE:

- One piece construction, .125 aluminum.
- Casters: 5" dia., swivel, modulus tires, 1-1/4 wide, load cap. 250 lbs. each, temp. range -45°/+180°F. Delrin bearings. Front casters equipped with brakes.

## DOOR:

- Field reversible.
- Formed 22 ga. stainless steel.
- Extruded handle.
- Transport latch.
- Hinges: Heavy duty chrome plated steel.
- Gasket: Perimeter type, magnetic Santoprene.
- Pan stop: Embossed.

## PAN SLIDES:

- Wire angles (.306 dia.), nickel chrome plated steel, mounted on lift-off posts.
- Spaced on 4-1/2" centers; adjustable on 1-1/2" centers.

## ELECTRICAL COMPONENTS:

- Thermostat: Pre-set to 38° F (3.3° C).
- Pilot light.
- Switch.
- Power cord: Permanent, 10 ft., 14/3 ga. with molded plug.
- Compressor: 1/3 h.p.
- Condensate evaporator: Electrical.
- R134a refrigerant.

## POWER REQUIREMENTS:

- 120 Volts, 60 Hz., single phase, 15 Amp. service.

## SHORT FORM SPECIFICATIONS

Cres Cor Refrigerated Cabinet Model R-171-SUA-10. Cabinet 22 ga. stainless steel; stainless steel internal frame. (10) sets of wire universal angles for multiple pan sizes, adjustable spacing every 1-1/2". Field reversible door, 22 ga. stainless steel. Fiberglass insulation in sides 2"; doors, base, top 1-1/2". Interior coved corners. 1/3 h.p. compressor, 120 Volts. One piece insulated base, .125 aluminum. 5" swivel casters, Delrin bearings. Load capacity 250 lbs. each. 2 year parts warranty. Provide the following accessories: \_\_\_\_\_ . CSA-US/C, CSA to NSF7 listed, ENERGY STAR Qualified.



5925 Heisley Road • Mentor, OH 44060-1833  
Phone: 877/CRESCOR • Fax: 440/350-7267  
www.crescor.com

© Crescent Metal Products, Inc. 2010 All rights reserved.

*In line with its policy to continually improve its products, CRES COR reserves the right to change materials and specifications without notice.*

Litho in U.S.A.