

SUPER SIZE HEATED DISH DOLLY MODEL HJ-531-13-180

FEATURES AND BENEFITS:

- Heated dish dolly for preheating 11-1/2" to 13" plates and platters prior to serving.
- Fits conveniently under standard 36" counters (height 32").
- Removable hinged top, front, and rear doors for easy access and cleaning.
- Equipped with 1000 Watt, 120 Volt heating element and lifetime lubricated blower motor. Provides quick heat up to 180°F (82°C).
- Recessed panel protects controls.
- Standard 6' twist-lock cord set.
- Base constructed of one piece, non-corrosive, Hi-Tensile aluminum with cross brace reinforcement for added strength.
- Heavy duty 5" swivel casters, two with brakes. Provides mobility when fully loaded.



HJ-531-13-180



ACCESSORIES and OPTIONS (Available at extra cost):

- Cord Wrap
- Perimeter Bumper
- Corner Bumpers
- 240 Volt Service

See page H-9 for accessory details.

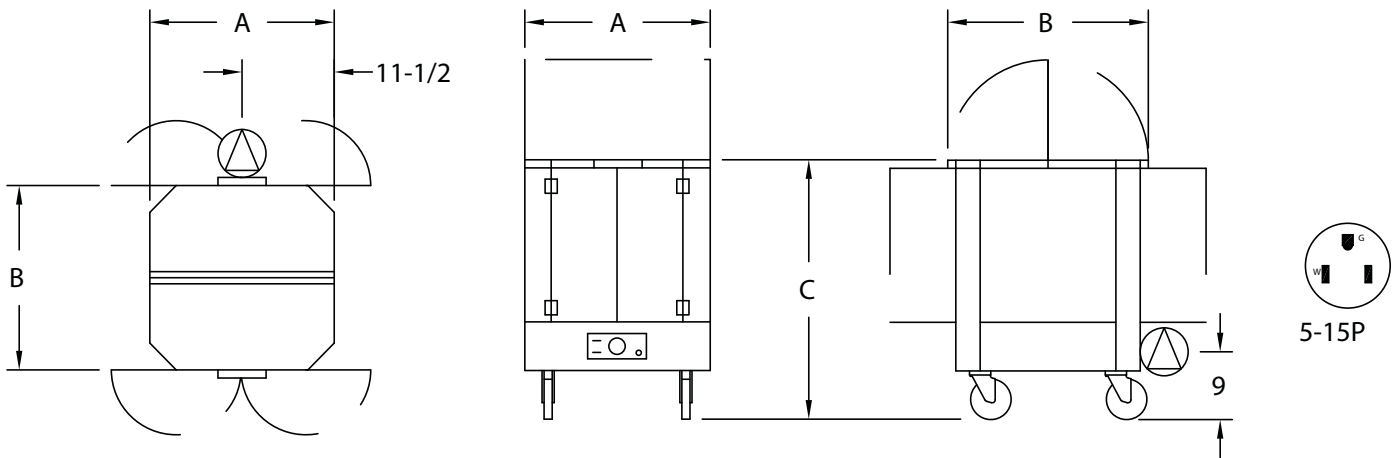

CRES COR MODEL NO.	*PLATE CAP.	DISH SIZE DIA.		DIM "A" WIDTH		DIM "B" DEPTH		DIM "C" HEIGHT		WEIGHT ACT.	
		INCHES	MM	INCHES	MM	INCHES	MM	INCHES	MM	LBS	KG
HJ-531-13-180	180	11-1/2 - 13	295 - 330	27-1/8	690	27-1/8	690	32	815	90	41

*Capacity shown is approximate; each compartment holds 20" (510 mm) stack of dishes.

ALL ALUMINUM CONSTRUCTION.

DOLLY:

- Base and louvered center partition: .100 aluminum.
- Center partition cover: .063 aluminum.
- Reinforcement: Formed .190 "X-frame" mounted to base.
- Corner posts: Extruded closed channels with air duct vents.
- Caster posts: Reinforced tubular extrusions.
- Casters: 5" dia., swivel, modulus tires, 1-1/4 wide, load cap. 250 lbs. each, temp. range -45°/+180°F. Delrin bearings. Two casters equipped with brakes.

TOP COVER:

- Panels: .100 aluminum connected with continuous hinge.
- Handles: .100 aluminum, riveted to two ends of cover.
- Removable; rests on four nesting pins riveted to sides.

DOUBLE DOORS:

- .100 aluminum.
- Latches: Zinc plated steel draw latch.
- Hinges: Nickel chrome plated steel, lift-off type.

ELECTRICAL COMPONENTS:

- Removable power cord: 6 ft., 14/3 ga. with molded plug.
- Heater: Incoloy sheath, 925 Watts.
- Thermostat: Electro-mechanical, room ambient to 180°F (82°C).
- Blower motor.

POWER REQUIREMENTS:

- 1000 Watts, 120 Volts, 60 Hz., single phase, 8.3 Amps., 15 Amp. service.

SHORT FORM SPECIFICATIONS

Cres Cor Heated Dish Dolly Model HJ-531-13-180 with .100 aluminum base and center post. Base reinforced with .190 aluminum "X" bracing. Body and doors constructed of .100 aluminum. 1000 Watt heater, blower motor, 120 Volts. Capacity of 240 plates 9-7/8" to 11" dia. Five inch swivel modulus casters have Delrin bearings. Load capacity 250 lbs. each. 2 year parts warranty. Provide the following accessories: _____ . CSA-US, CSA-C, NSF listed.



5925 Heisley Road • Mentor, OH 44060-1833
 Phone: 877/CRESCOR • Fax: 440/350-7267
 www.crescor.com

© Crescent Metal Products, Inc. 2008 All rights reserved.

In line with its policy to continually improve its products, CRES COR reserves the right to change materials and specifications without notice.

Litho in U.S.A.