

**INSULATED UNDERCOUNTER
HOT CABINET
MODEL H-339-XUA-8C
(FOR A VARIETY OF PAN SIZES)**

FEATURES AND BENEFITS:

- Fully insulated undercounter hot cabinet keeps prepared foods at serving temperatures. Ideal for transport
- Powerful, yet efficient, 900 Watt heating system maintains the right temperature to properly hold products. Heats up to 200°F (93°C).
- Internal frame in body and door maintains structural rigidity.
- Body constructed of non-corrosive, Hi-Tensile aluminum for strength and ease of mobility. One piece extended base protects cabinet body.
- Safety-conscious anti-microbial latch protect against spreading germs.
- Insulated field reversible door for flexibility. Standard with right hand hinging; left hand hinging available upon request.
- Magnetic latch for "easy open"; twist-lock catch secures door during transport. Latch and hinges mounted inboard.
- Eight sets of chrome plated wire universal angles accommodate a large variety of pan sizes on adjustable 1-1/2" centers.
- Pan stops on inside of door and back allow for proper air flow.
- Heavy duty 3" swivel casters, two with brakes. Provides mobility when fully loaded.



H-339-XUA-8C



NSF/ANSI 4



C US

**ACCESSORIES and OPTIONS
(Available at extra cost):**

- Key Lock Handle
- Extra Universal Angles
- Change from standard universal angles to universal angles designed for transporting
- Corner Bumpers
- Perimeter Bumper
- Digital Thermometer
- 240 Volt Service

See page B-20 for accessory details.

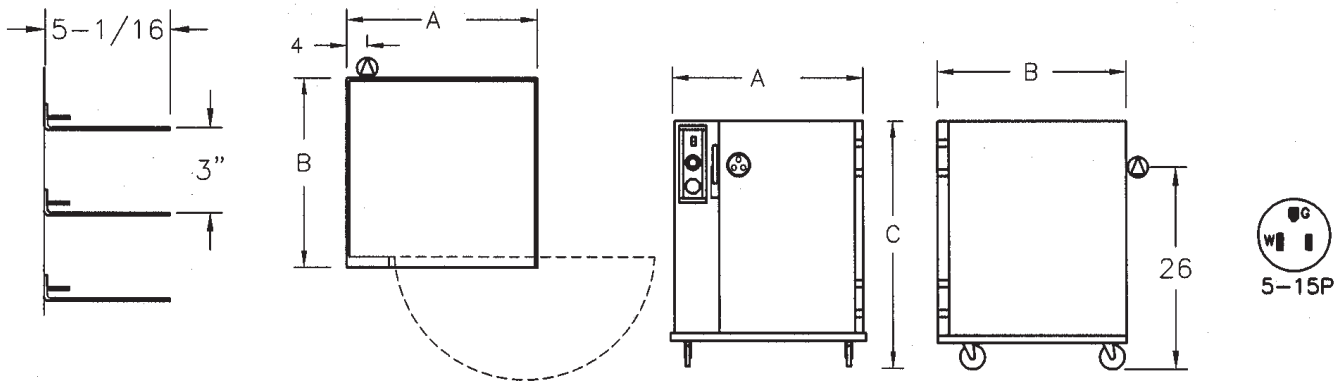

DETAIL OF PAN SLIDE

CRES COR MODEL NO.	PAN			DIM "A"	DIM "B"	DIM "C"	INSIDE DIMENSIONS				WEIGHT ACT.
	CAP/ ANGLES	SIZE		WIDTH	DEPTH	HEIGHT	WIDTH	DEPTH	HEIGHT		
H-339-XUA-8C	8 SETS	SEE NOTE BELOW	IN	31-7/8	32-1/4	32-1/4	21-3/4	26-1/4	24-7/8	LBS	155
			MM	810	820	820	555	670	635	KG	70

NOTES: 1. Pan sizes 22" x 20" (560 x 510) Roast & Bake Pans, 10" x 20" (255 x 510) Roast & Bake Pans, 18" x 26" (460 x 660) Bun Pans, 14" x 18" (355 x 460) Service Trays, 12" x 20" (305 x 510) Steam Table Pans.
Refer to Pan Size Chart at end of section.

2. When ordering bumpers, add 2" to overall dimensions.

ALL ALUMINUM CONSTRUCTION IS RIVETED, WELDED AND FINISHED.

CABINET:

- Body: .063 aluminum.
- Reinforcement: Internal framework of channels, 1 x 3/4 x .125.
- Insulation: Fiberglass, thermal conductivity (K factor) is .23 at 75°F. 1-1/2" in walls; 1" in door, top and bottom.
- Pan stop channels: Mounted to inside rear of cabinet and door.

BASE:

- One piece construction, .125 aluminum.
- Casters: 3" dia., swivel, modulus tires, 1-1/4 wide, load cap. 240 lbs. each, temp. range -45°/+180°F. Bearings are sealed and permanently lubricated. Front casters equipped with brakes.

DOOR:

- Field reversible.
- Formed .063 aluminum.
- Latch: Chrome plated zinc with composite handle, magnetic type; mounted inboard.
- Hinges: Heavy duty chrome plated zinc; mounted inboard.
- Gasket: Perimeter type, silicone.
- Transport latch.
- Vent: Adjustable.

PAN SLIDES:

- Wire angles (.306 dia.) nickel chrome plated steel; spaced on 3" centers, adjustable on 1-1/2" centers.

ELECTRICAL COMPARTMENT:

- Control panel: Formed .063 aluminum; black front.
- Thermostat: Electro-mechanical, room ambient to 200°F (93°C).
- Switch: Lighted ON-OFF rocker type.
- Power cord: Permanent, 6 ft., 14/3 ga. with molded straight plug.
- Heaters (3): 300 Watts each.
- Thermometer.

POWER REQUIREMENTS:

- 900 Watts, 120 Volts, 60 Hz., single phase, 7.5 Amps., 15 Amp. service.

SHORT FORM SPECIFICATIONS

Cres Cor Insulated Under Counter Hot Cabinet Model H-339-XUA-8C. Inner, outer and top liners of .063 aluminum, reinforced with channel frame. Field reversible, formed .063 aluminum door. Fiberglass insulation in walls 1-1/2"; door, top and bottom 1". Welded and finished .125 aluminum base. (3) 300 Watt inner wall heaters, 120 Volts. (8) sets wire universal angles for multiple pan sizes, adjustable spacing every 1-1/2". 3" swivel modulus casters, permanently lubricated. Load capacity 240 lbs. each. 2 year parts warranty. Provide the following accessories: _____ . CSA-US, CSA-C, CSA to NSF4 listed. Energy Star Qualified.



5925 Heisley Road • Mentor, OH 44060-1833
Phone: 877/CRESCOR • Fax: 440/350-7267
www.crescor.com

© Crescent Metal Products, Inc. 2006 All rights reserved.

In line with its policy to continually improve its products, CRES COR reserves the right to change materials and specifications without notice.

Litho in U.S.A.