

INSULATED HALF-SIZE STAINLESS STEEL HOT CABINETS H-339-SS SERIES (FOR 18" X 26" PANS)

FEATURES AND BENEFITS:

- Fully insulated undercounter hot cabinet keeps prepared foods at serving temperatures.
- Powerful, yet efficient, 900 Watt heating system maintains the right temperature to properly hold products. Heats up to 200°F (93°C).
- Internal frame in body and door maintains structural rigidity.
- Stainless steel construction throughout for ease of cleaning. One piece extended base protects cabinet body.
- Safety-conscious anti-microbial latch protect against spreading germs.
- Insulated field reversible door for flexibility. Standard with right hand hinging; left hand hinging available upon request.
- Magnetic latch for "easy open"; twist-lock catch secures door during transport. Latch and hinges mounted inboard.
- Removable pan supports for easy cleaning. Models available:
 - Wire supports for 18" x 26" pans on 2-3/4" centers. Model H-339-SS-188C
 - Wire supports for 18" x 26" pans and 12" x 20" pans on 2-3/4" centers. Model H-339-SS-12-188C
 - Corrugated supports for 18" x 26" pans on 1-1/2" centers. Model H-339-SS-1813C
- Pan stops on inside of door and back allow for proper air flow.
- Convenient lift handles fold flat against sides of cabinet.
- Heavy duty 5" swivel casters, two with brakes. Provides mobility when fully loaded.
- Cabinets can be stacked for flexibility; specify optional stacking kit.



H-339-SS-12-188C



NSF/ANSI 4



c US

ACCESSORIES and OPTIONS (Available at extra cost):

- Key Lock Handle
- Stacking Kit
- Corner Bumpers
- Perimeter Bumper
- Various Caster Options
- Digital Thermometer
- 240 Volt Service

See page B-20 for accessory details.

H-339-SS Series (18" x 26" Pans)

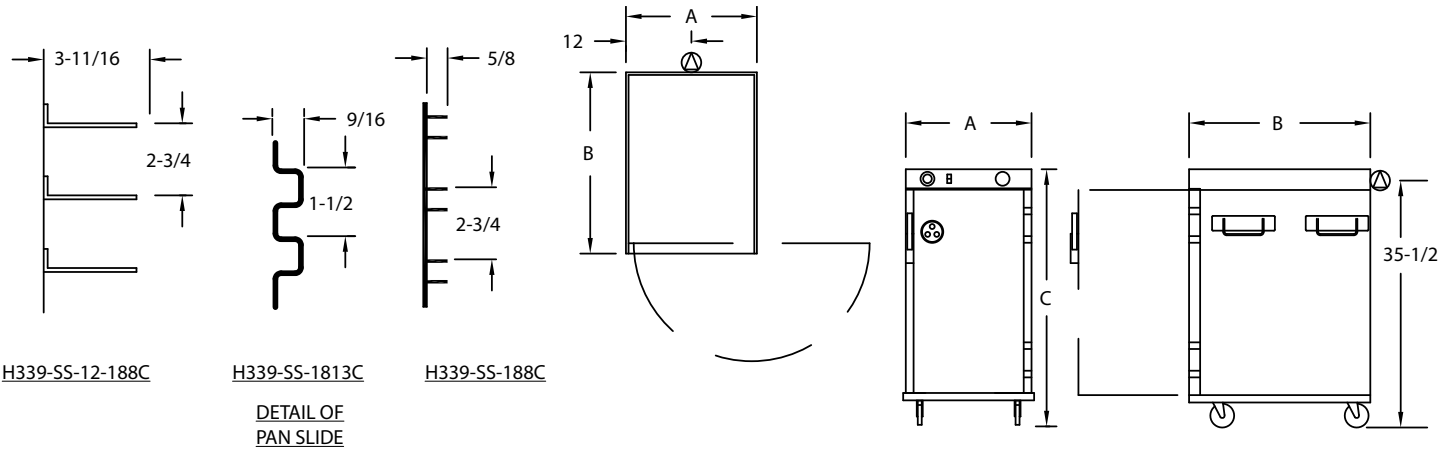

CRES COR MODEL NO.	PAN			DIM "A" WIDTH	DIM "B" DEPTH	DIM "C" HEIGHT	INSIDE DIMENSIONS			WEIGHT ACT.	
	CAP	SIZE					WIDTH	DEPTH	HEIGHT		
H-339-SS-188C	8	18 x 26	IN	23-7/8	32-1/4	36-11/16	18-3/16	26-1/4	24-7/8	LBS	190
		460 x 660	MM	610	820	935	465	670	635	KG	86
H-339-SS-12-188C	8*	18 x 26	IN	23-7/8	32-1/4	36-11/16	18-3/16	26-1/4	24-7/8	LBS	190
		460 x 660	MM	610	820	935	465	670	635	KG	86
H-339-SS-1813C	13	18 x 26	IN	23-7/8	32-1/4	36-11/16	18-3/16	26-1/4	24-7/8	LBS	190
		460 x 660	MM	610	820	935	465	670	635	KG	86

NOTES: 1. Will also carry 12" x 20" pans, capacity 8.
 2. When ordering bumpers, add 2" to overall dimensions.
 ALL CONSTRUCTION IS RIVETED, WELDED AND FINISHED.

CABINET:

- Body: 22 ga. stainless steel.
- Reinforcement: Internal framework of channels, 1 x 3/4 x .125.
- Insulation: Fiberglass, thermal conductivity (K factor) is .23 at 75°F. 1-1/2" in walls; 1" in door, top and bottom.
- Pan stop channels: Mounted to inside rear of cabinet and door.
- Bail handles (4): Two mounted to each side.

BASE:

- One piece construction, .190 aluminum.
- Casters: 5" dia., swivel, modulus tires, 1-1/4 wide, load cap. 250 lbs. each, temp. range -45°/+180°F. Delrin bearings. Front casters equipped with brakes.

DOOR:

- Field reversible.
- Formed 22 ga. stainless steel.
- Latch: Chrome plated zinc with composite handle, magnetic type; mounted inboard.
- Hinges: Heavy duty chrome plated zinc; mounted inboard.
- Gasket: Perimeter type, silicone.
- Transport latch.
- Vent: Adjustable.

PAN SLIDES:

- H-339-SS-188C, H-339-SS-12-188C: Flat wire racks, .104 x 5/8 nickel chrome plated steel, spaced on 2-3/4" centers.
- H-339-SS-1813C: Corrugations act as pan slides on 1-1/2" centers.

ELECTRICAL COMPARTMENT:

- Cover: Formed 18 ga. stainless steel fastened to cabinet top.
- Control panel: Formed .063 aluminum; black front.
- Thermostat: Electro-mechanical, room ambient to 200°F (93°C).
- Switch: Lighted ON-OFF rocker type.
- Power cord: Removable, 6 ft., 14/3 ga. with molded straight plug.
- Heaters (3): 300 Watts each.
- Thermometer.

POWER REQUIREMENTS:

- 900 Watts, 120 Volts, 60 Hz., single phase, 7.5 Amps., 15 Amp. service.

SHORT FORM SPECIFICATIONS

Cres Cor Insulated Half-Size Hot Cabinet Model H-339-SS-____C. Cabinet and door 22 ga. stainless steel; reinforced with channel frame. Field reversible door. Fiberglass insulation in walls 1-1/2"; door, top and bottom 1". Welded and finished .190 aluminum base. (3) 300 Watt inner wall heaters, 120 Volts. Removable pan supports for (____) 18" x 26" pans or (____) 12" x 20" pans. Two bail handles on each side. 5" swivel modulus casters, Delrin bearings. Load capacity 250 lbs. each. 2 year parts warranty. Provide the following accessories: _____ . CSA-US, CSA-C, CSA to NSF4 listed.



5925 Heisley Road • Mentor, OH 44060-1833
 Phone: 877/CRESCOR • Fax: 440/350-7267
 www.crescor.com

© Crescent Metal Products, Inc. 2010 All rights reserved.

In line with its policy to continually improve its products, CRES COR reserves the right to change materials and specifications without notice.

Litho in U.S.A.