

**INSULATED COUNTER TOP
HOT CABINET
MODEL H-339-12-135C
(FOR 12" X 20" OR 13" X 18" PANS)**

FEATURES AND BENEFITS:

- Fully insulated counter top hot cabinet keeps prepared foods at serving temperatures. Ideal for under counter use also.
- Powerful, yet efficient, 900 Watt heating system maintains the right temperature to properly hold products. Heats up to 200°F (93°C).
- Internal frame in body and door maintains structural rigidity.
- Body constructed of non-corrosive, Hi-Tensile aluminum for strength and ease of mobility.
- Safety-conscious anti-microbial latch protect against spreading germs.
- Insulated field reversible door for flexibility. Standard with right hand hinging; left hand hinging available upon request.
- Magnetic latch for "easy open"; Latch and hinges mounted inboard.
- Pan slides securely hold (5) 12" x 20" x 2-1/2" or (5) 13" x 18" pans on 2-3/4" centers; removable for easy cleaning.
- Pan stops on inside of door and back allow for proper air flow.
- Mounted on 4" legs to allow for counter top cleaning.



H-339-12-135C



NSF/ANSI 4



**ACCESSORIES and OPTIONS
(Available at extra cost):**

- Transport Kit (solid base, casters, side lift handles, twist-lock latch)
- Pass-Thru
- Stainless Steel
- Corner Bumpers
- Digital Thermometer
- Caster Kit
- 240 Volt Service

See page B-20 for accessory details.

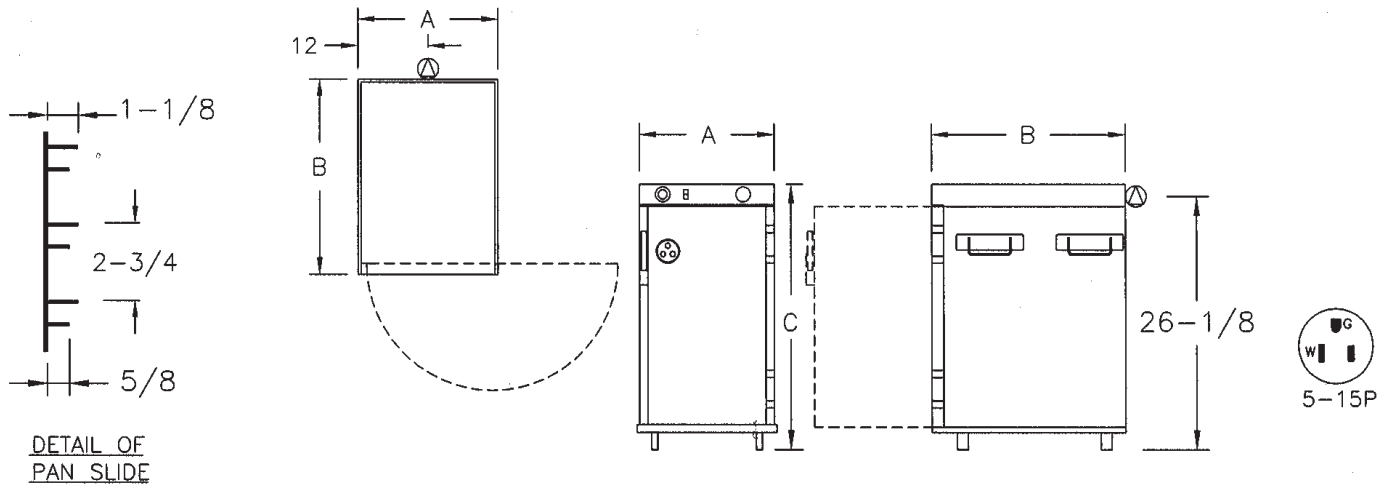

CRES COR MODEL NO.	PAN			DIM "A"	DIM "B"	DIM "C"	INSIDE DIMENSIONS			WEIGHT ACT.	
	CAP	SIZE		WIDTH	DEPTH	HEIGHT	WIDTH	DEPTH	HEIGHT		
H-339-12-135C	5	12 x 20	IN	17-7/8	25-1/4	27-9/16	13-3/16	21-1/4	17-7/8	LBS	95
		305 x 510	MM	455	645	700	335	540	455	KG	43.1
	5	13 x 18	IN								
		330 x 460	MM								

ALL CONSTRUCTION IS RIVETED, WELDED AND FINISHED.

CABINET:

- Body: .063 aluminum.
- Reinforcement: Internal framework of channels, 1 x 3/4 x .125.
- Insulation: Fiberglass, thermal conductivity (K factor) is .23 at 75°F. 1-1/2" in walls; 1" in door, top and bottom.
- Pan stop channels: Mounted to inside rear of cabinet and door.
- Legs (4): 4" high, black.

DOOR:

- Field reversible.
- Formed .063 aluminum.
- Latch: Chrome plated zinc with composite handle, magnetic type; mounted inboard.
- Hinges: Heavy duty chrome plated zinc; mounted inboard.
- Gasket: Perimeter type, silicone.
- Vent: Adjustable.

PAN SLIDES:

- 18 ga. 304 stainless steel channels on 2-3/4" centers.
- Mounted to removable 16 ga. 304 stainless steel post.

ELECTRICAL COMPARTMENT:

- Cover: Formed .100 aluminum fastened to cabinet top.
- Control panel: Formed .063 aluminum; black front.
- Thermostat: Electro-mechanical, room ambient to 200°F (93°C).
- Switch: Lighted ON-OFF rocker type.
- Power cord: Permanent, 6 ft., 14/3 ga. with molded straight plug.
- Heaters (3): 300 Watts each.
- Thermometer.

POWER REQUIREMENTS:

- 900 Watts, 120 Volts, 60 Hz., single phase, 7.5 Amps., 15 Amp. service.

SHORT FORM SPECIFICATIONS

Cres Cor Insulated Counter Top Hot Cabinet Model H-339-12-135C. Inner, outer and top liners of .063 aluminum, reinforced with channel frame. Field reversible, formed .063 aluminum door. Fiberglass insulation in walls 1-1/2"; door, top and bottom 1". Welded and finished. (3) 300 Watt inner wall heaters, 120 Volts. Removable pan supports for (5) 12" x 20" pans or (5) 13" x 26" pans. Mounted on 4" high legs. 2 year parts warranty. Provide the following accessories: _____ . CSA-US, CSA-C, CSA to NSF4 listed. Energy Star Qualified.



5925 Heisley Road • Mentor, OH 44060-1833
 Phone: 877/CRESCOR • Fax: 440/350-7267
 www.crescor.com

© Crescent Metal Products, Inc. 2008 All rights reserved.

In line with its policy to continually improve its products, CRES COR reserves the right to change materials and specifications without notice.

Litho in U.S.A.