

INSULATED HOT CABINET MODEL H-138-1834C

FEATURES AND BENEFITS:

- Fully insulated hot cabinet keeps prepared foods at serving temperatures.
- Powerful, yet efficient, 1500 Watt heating system with humidity pan maintains the right temperature to properly hold products. Heats up to 200°F (93°C).
- Self-contained power top allows interior of cabinet to be hosed-out during cleaning.
- Internal frame in body maintains structural rigidity.
- Body constructed of non-corrosive, Hi-Tensile aluminum for strength and ease of mobility. One piece extended base protects cabinet body.
- Smooth interior coved corners prevent food particle/grease buildup.
- Self-closing insulated Dutch doors prevent temperature loss; magnetic door gaskets for proper seal. Field reversible for flexibility.
- Standard with right hand hinging; left hand hinging available upon request.
- Safety-conscious anti-microbial latches protect against spreading germs.
- Full length extruded door handles for “easy open”; positive catch secures door during transport.
- Recessed push/pull handles on both sides prevents damage to walls; allows easy maneuvering.
- Channel pan slides securely hold 18" x 26" pans on 1-1/2" centers without tipping.
- Heavy duty 5" swivel casters, two with brakes. Provides mobility when fully loaded.



H-138-1834C



ACCESSORIES and OPTIONS (Available at extra cost):

- Tempered Glass Door Windows
- Corner Bumpers
- Perimeter Bumper
- Floor Lock (for use with 5" casters)
- Various Caster Options
- Removable Cord Set
- 208 or 240 Volt Service
- Food Safe Digital Thermometer
- Magnetic Door Latch
- Upgrade to 2000 Watt Power Unit

See page B-20 for accessory details.

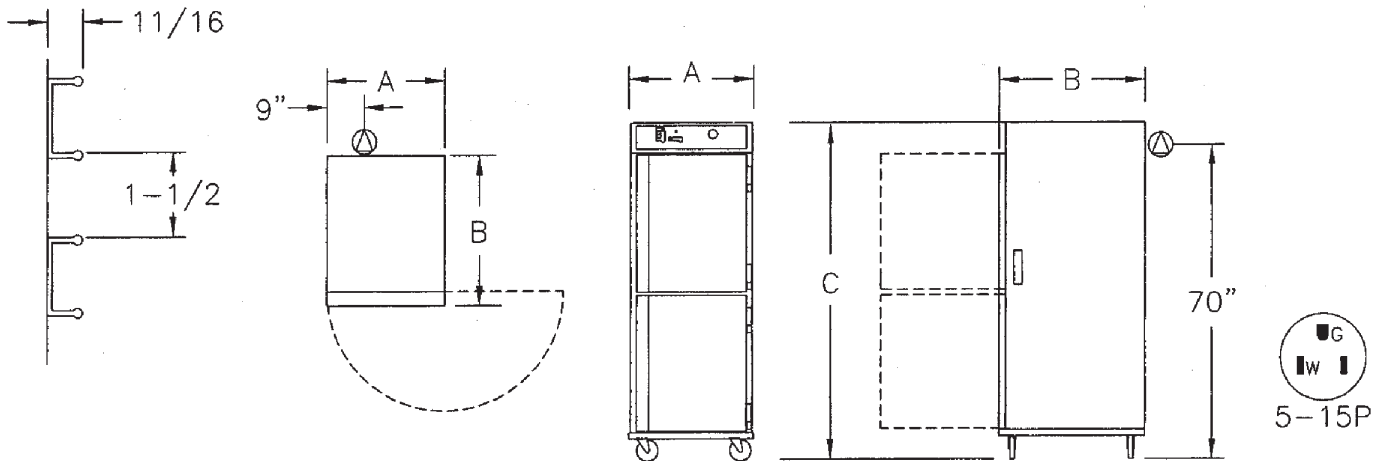

CRES COR MODEL NO.	PAN			DIM "A"	DIM "B"	DIM "C"	INSIDE DIMENSIONS			WEIGHT ACT.	
	CAP	SIZE		WIDTH	DEPTH	HEIGHT	WIDTH	DEPTH	HEIGHT		
H-138-1834C	32	18 X 26	IN	28-3/4	34-3/16	73	18-1/16	27-1/2	58	LBS	245
		460 X 660	MM	730	870	1855	460	700	1475	KG	111

NOTES: 1. Send sample pan or tray with order when using any that are not 18" x 26" pans with heavy beaded edges.
 2. When ordering bumpers, add 2" to overall dimensions.

ALL ALUMINUM CONSTRUCTION IS RIVETED, WELDED AND FINISHED.

CABINET:

- Body: .063 aluminum.
- Reinforcement: Internal framework of 18 ga. stainless steel.
- Insulation: Fiberglass, thermal conductivity (K factor) is .23 at 75°F. 1-1/2" in doors, top, base; 2" in sidewalls.
- Air tunnel: 22ga. stainless steel; lift-out type, mounted on back.
- Push/pull handles (2): 5" vertical; recessed.
- Interior coved corners.

BASE:

- One piece construction, .125 aluminum.
- Casters: 5" dia., swivel, modulus tires, 1-1/4 wide, load cap. 250 lbs. each, temp. range -45°/+180°F. Delrin bearings. Front casters equipped with brakes.

DUTCH DOORS:

- Field reversible.
- Exterior: .063 brushed aluminum.
- Interior: 22 ga. stainless steel.
- Latches: Positive transport type with lock hasp.
- Extruded handles.
- Hinges: Self closing, stays open past 90°.
- Gaskets: Perimeter type, magnetic Santoprene.
- Pan stops.

PAN SLIDES:

- Channels: Extruded aluminum, 11/16 x 1-1/2 x .100, riveted on 1-1/2" centers.

HOT UNIT COMPONENTS:

- Top mounted; removable with tools.
- Thermostat: Mechanical, room ambient to 200°F (93°C).
- Switch: ON-OFF rocker type.
- Power light
- Power cord: Permanent, 10 ft., 14/3 ga.
- Heater: 1470 Watts.
- Blower motor.
- Vent fan.
- Thermometer: Analog

POWER REQUIREMENTS:

- 1500 Watts, 120 Volts, 60 Hz., single phase, 12 Amps., 15 Amp. service.

SHORT FORM SPECIFICATIONS

Cres Cor Insulated Hot Cabinet Model H-138-1834C. Inner, outer and top liners of .063 aluminum; stainless steel internal frame. No-tip .100 aluminum channel slides for (32) 18" x 26" pans on 1-1/2" centers. Field reversible Dutch doors, outer .063 brushed aluminum, inner 22 ga. stainless steel. Fiberglass insulation in sides 2"; doors, top, base 1-1/2". Interior coved corners. Hose out cleaning capability. 1500 Watt, 120 Volt power unit. One piece base, .125 aluminum. 5" swivel modulus casters, Delrin bearings. Load capacity 250 lbs. each. 2 year parts warranty. Provide the following accessories:
 ____ . NSF, CSA-US, CSA-C listed.



5925 Heisley Road • Mentor, OH 44060-1833
 Phone: 877/CRESCOR • Fax: 440/350-7267
 www.crescor.com

© Crescent Metal Products, Inc. 2010 All rights reserved.

In line with its policy to continually improve its products, CRES COR reserves the right to change materials and specifications without notice.

Litho in U.S.A.