

## INSULATED STAINLESS STEEL HOT CABINET MODEL H-137-SUA-12C

### FEATURES AND BENEFITS:

- Fully insulated hot cabinet keeps prepared foods at serving temperatures.
- Powerful, yet efficient, 1500 Watt heating system maintains the right temperature to properly hold products. Heats up to 200°F (93°C).
- Self-contained power top allows interior of cabinet to be hosed-out during cleaning.
- Internal frame in body maintains structural rigidity.
- Stainless steel construction throughout for ease of cleaning. One piece extended base protects cabinet body.
- Smooth interior coved corners prevent food particle/grease buildup.
- Safety-conscious anti-microbial latches protect against spreading germs.
- Field reversible insulated Dutch doors prevent temperature loss. Silicone door gaskets for proper seal.
- Standard with right hand hinging; left hand hinging available upon request.
- High temperature ceramic magnetic latches for "easy open"; twist-lock catch secures door during transport. Latches and hinges mounted inboard.
- Recessed push/pull handles on both sides prevents damage to walls; allows easy maneuvering.
- Twelve sets of chrome plated wire universal angles accommodate a large variety of pan sizes on adjustable 1-1/2" centers.
- Heavy duty 5" swivel casters, two with brakes. Provides mobility when fully loaded.



H-137-SUA-12C



### ACCESSORIES and OPTIONS (Available at extra cost):

- Tempered Glass Door Windows
  - Key Lock Handle
  - Lock Hasp
  - Extra Universal Angles
  - Change from standard chrome plated wire angles to angles designed for transporting
  - Change from chrome plated wire angles to extruded aluminum or formed stainless steel angles.
  - Corner Bumpers
  - Perimeter Bumper
  - Floor Lock (for use with 5" casters)
  - Various Caster Options
  - Removable Cord Set
  - 208 or 240 Volt Service
  - Food Safe Digital Thermometer
  - Upgrade to 2000 Watt Power Unit
- See page B-20 for accessory details.

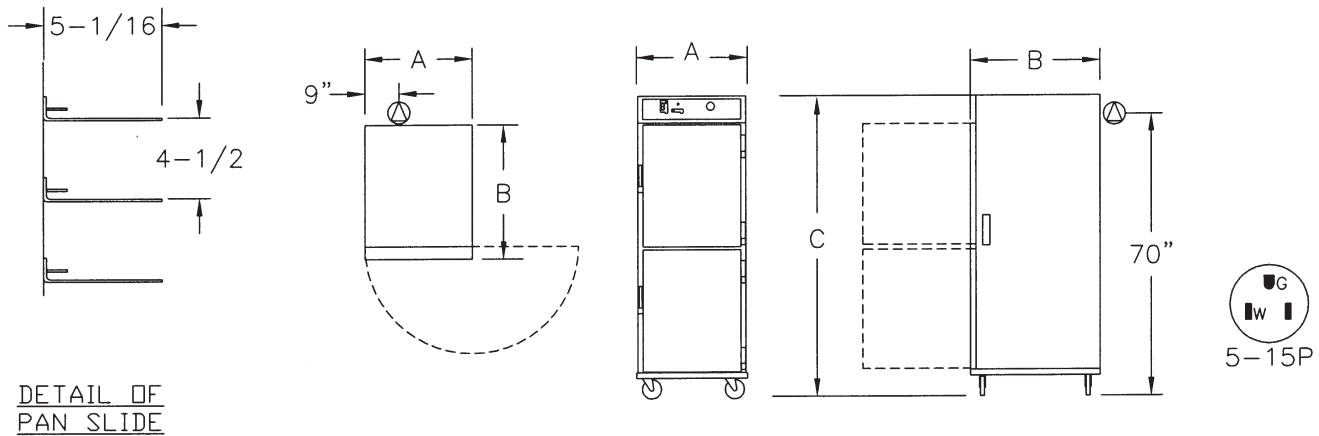

DETAIL OF PAN SLIDE

CRES COR MODEL NO.	PAN			DIM "A"	DIM "B"	DIM "C"	INSIDE DIMENSIONS				WEIGHT ACT.
	CAP/ ANGLES	SIZE		WIDTH	DEPTH	HEIGHT	WIDTH	DEPTH	HEIGHT		
H-137-SUA-12C	12 SETS	SEE NOTE BELOW	IN	28-3/4	34-3/16	73	22	27-1/2	58	LBS	283
			MM	730	870	1855	560	700	1475	KG	128

NOTES: 1. Pan sizes 22" x 20" (560 x 510) Roast & Bake Pans, 10" x 20" (255 x 510) Roast & Bake Pans, 18" x 26" (460 x 660) Bun Pans, 14" x 18" (355 x 460) Service Trays, 12" x 20" (305 x 510) Steam Table Pans.  
Refer to Pan Size Chart at end of section.

2. When ordering bumpers, add 2" to overall dimensions.

ALL CONSTRUCTION IS RIVETED, WELDED AND FINISHED.

**CABINET:**

- Body: 22 ga. stainless steel.
- Reinforcement: Internal framework of 18 ga. stainless steel.
- Insulation: Fiberglass, thermal conductivity (K factor) is .23 at 75°F. 1-1/2" in doors, base top; 2" in sidewalls.
- Air tunnel: 22 ga. stainless steel; lift-out type, mounted on back.
- Push/pull handles (2): 5" vertical; recessed.
- Interior coved corners.

**BASE:**

- One piece construction, .125 aluminum.
- Casters: 5" dia., swivel, modulus tires, 1-1/4 wide, load cap.
- 250 lbs. each, temp. range -45°/+180°F. Delrin bearings. Front casters equipped with brakes.

**DUTCH DOORS:**

- Field reversible.
- Formed 22 ga. stainless steel.
- Latches: Chrome plated steel, high temperature ceramic magnetic type, mounted inboard.
- Transport latches
- Hinges: Heavy duty chrome plated steel.
- Gaskets: Perimeter type, silicone.
- Pan stops: Embossed.

**PAN SLIDES:**

- Wire angles (.306 dia.), nickel chrome plated steel, mounted on lift-off posts.
- Spaced on 4-1/2" centers; adjustable on 1-1/2" centers.

**HOT UNIT COMPONENTS:**

- Top mounted: removable with tools.
- Thermostat: Mechanical, room ambient to 200°F (93°C).
- Switch: ON-OFF rocker type.
- Power light.
- Power cord: Permanent, 10 ft., 14/3 ga.
- Heater: 1470 Watts.
- Blower motor.
- Vent Fan.
- Thermometer: Analog

**POWER REQUIREMENTS:**

- 1500 Watts, 120 Volts, 60 Hz., single phase, 12 Amps., 15 Amp. service.

**SHORT FORM SPECIFICATIONS**

Cres Cor Insulated Hot Cabinet Model H-137-SUA-12C. Cabinet 22 ga. stainless steel; stainless steel internal frame. (12) sets wire universal angles for multiple pan sizes, adjustable spacing every 1-1/2". Field reversible Dutch doors, 22 ga. stainless steel. Fiberglass insulation in sides, 2"; doors, base, top 1-1/2". Interior coved corners. Hose out cleaning capability. 1500 Watt, 120 Volt power unit. One piece insulated base, .125 aluminum. 5" swivel modulus casters, Delrin bearings. Load capacity 250 lbs. each. 2 year parts warranty. Provide the following accessories: \_\_\_\_\_. NSF, CSA-US, CSA-C listed.



5925 Heisley Road • Mentor, OH 44060-1833  
Phone: 877/CRESCOR • Fax: 440/350-7267  
www.crescor.com

© Crescent Metal Products, Inc. 2008 All rights reserved.

*In line with its policy to continually improve its products, CRES COR reserves the right to change materials and specifications without notice.*

Litho in U.S.A.