

INSULATED HEATED STAINLESS STEEL BANQUET CABINET MODEL H-137-S-96-BC (FOR COVERED MEALS)

FEATURES AND BENEFITS:

- Fully insulated banquet cabinet designed to hold plated covered meals.
- Upright design save floor space.
- Internal frame in body for structural rigidity.
- 300 Series stainless steel construction throughout for ease of cleaning.
- Smooth interior coved corners prevent food particle/grease buildup.
- Field reversible insulated door swings 270° for ease of loading and unloading.
- Paddle latch and hinges are mounted inboard.
- Recessed push/pull handles on both sides prevents damage to walls; allows easy maneuvering.
- Supplied with five shelves fixed on 11-3/8" centers. Slide out for easy access to contents.
- Powerful, yet efficient, 1500 Watt heating system maintains the right temperature to properly hold products. Heats up to 200°F. (93°C.).
- Self-contained power top allows interior of cabinet to be hosed-out during cleaning.
- Welded and finished one-piece base with perimeter bumper protects cabinet body.
- Heavy duty 5" swivel casters, two with brakes. Provides mobility when fully loaded.



H-137-S-96-BC



ACCESSORIES and OPTIONS (Available at extra cost):

- Gravity Transport Latch
- Floor Lock (for use with 5" casters)
- Various Caster Options
- Removable Cord Set
- 208 or 240 Volt Service
- Upgrade to 2000 Watt Power Unit

See page F-4 for accessory details.

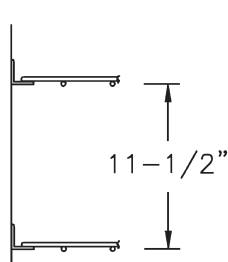

DETAIL OF PAN SLIDE

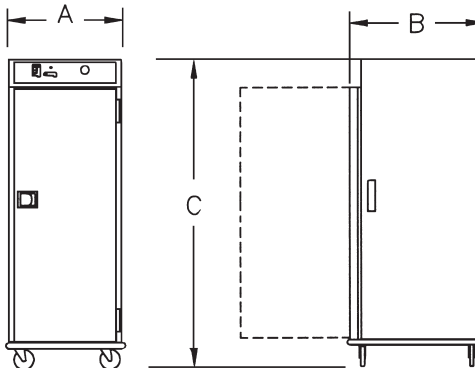
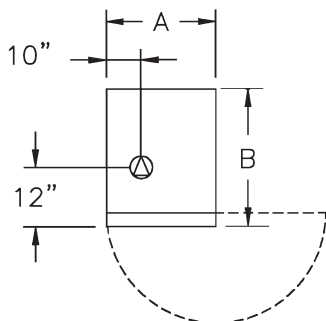

CRES COR MODEL NO.	MEAL CAP		DIM "A"	DIM "B"	DIM "C"	INSIDE DIMENSIONS				WEIGHT ACT.
			WIDTH	DEPTH	HEIGHT	WIDTH	DEPTH	HEIGHT		
H-137-S-96-BC	96	IN	31-1/2	45-1/2	76-3/4	24-1/4	38	61-1/2	LBS	365
		MM	800	1155	1950	620	965	1565	KG	166

Capacity based on covered plates to 12" dia. with nesting height of 3" for plate and cover.
 ALL CONSTRUCTION IS RIVETED, WELDED AND FINISHED.

CABINET:

- Body: 22 ga. 300 Series stainless steel.
- Reinforcement: Internal framework of 18 ga. 300 Series stainless steel.
- Air tunnel: 22 ga. stainless steel; mounted on back, lifts out.
- Insulation: Fiberglass, thermal conductivity (K factor) is .23 at 75°F. 1-1/2" in doors, top, base; 2" in sidewalls.
- Push/pull handles (2): 5" vertical; recessed.
- Interior coved corners.

BASE:

- One piece construction, .125 aluminum.
- Casters: 5" dia., swivel, modulus tires, 1-1/4 wide, load cap. 250 lbs. each, temp. range -45°/+180°F. Delrin bearings. Front casters equipped with brakes.
- Perimeter bumper: Gray, non-marking rubber, 1 x 1.

DOOR:

- Field reversible.
- Formed 22 ga. 300 Series stainless steel.
- Latch: Polished stainless steel, slam type; mounted inboard.
- Transport latches.
- Hinges: Heavy duty stainless steel; 270° swing.
- Gasket: Perimeter type, silicone.

SHELVES:

- Five shelves: Each shelf made up of nickel chrome plated steel wire grids, 24-1/4 x 36; held by 1 x 1 16 ga., 304 stainless steel clips fixed on 11-3/8" centers.

HOT UNIT COMPONENTS:

- Top mounted; removable with tools.
- Thermostat: Mechanical, room ambient to 200°F. (93°C.).
- Power Light
- Switch: ON-OFF Rocker type.
- Power cord: Permanent, 10 ft., 14/3 ga. with metal strain relief.
- Heater: 1470 Watts.
- Blower motor.
- Vent fan.
- Thermometer: Analog.

POWER REQUIREMENTS:

- 1500 Watts, 125 Volts, 60 Hz., single phase, 12 Amps., 15 Amp. service.

SHORT FORM SPECIFICATIONS

Cres Cor Heated Banquet Cabinet Model H-137-S-96-BC. 22 ga. stainless steel. Field reversible door, 22 ga. stainless steel. Fiberglass insulation in sides 2"; door, top, base 1-1/2". Interior coved corners. Hose out cleaning capability. five nickel chrome plated wire grids. Capacity 96 covered meals. Base one piece .125 aluminum, welded and finished, perimeter bumper. 5" swivel casters, Delrin bearings. Load capacity 250 lbs. each. 1500 Watts, 125 Volts, 60 Hz., 1 Phase, 15 Amp. Service. 2 year parts warranty. Provide the following accessories: _____. UL, UL Sanitation, CUL listed, Energy Star Qualified.



5925 Heisley Road • Mentor, OH 44060-1833
 Phone: 877/CRESCOR • Fax: 440/350-7267
 www.crescor.com

© Crescent Metal Products, Inc. 2006 All rights reserved.

In line with its policy to continually improve its products, CRES COR reserves the right to change materials and specifications without notice.

Litho in U.S.A.