

INSULATED STAINLESS STEEL HOT CABINET MODEL H-137-PSUA-12C

FEATURES AND BENEFITS:

- Fully insulated hot cabinet keeps prepared foods at serving temperatures. Ideal for fried foods.
- Pass-thru design allows for access from preparation and serving areas.
- Powerful, yet efficient, 2000 Watt heating system maintains the right temperature to properly hold products. Heats up to 200°F (93°C).
- Control panel has easy-to-read thermometer; self-contained power top allows interior of cabinet to be hosed-out during cleaning.
- Internal frame in body for structural rigidity.
- 304 stainless steel construction throughout for ease of cleaning. One piece extended base protects cabinet body.
- Smooth interior coved corners prevent food particle/grease buildup.
- Safety-conscious anti-microbial latches protect against spreading germs.
- Insulated Dutch doors on front and back of cabinet prevent temperature loss. Field reversibility for flexibility.
- Standard with right hand hinging; left hand hinging available upon request.
- High temperature ceramic magnetic latches for "easy open"; twist-lock catch secures door during transport. Latches and hinges mounted inboard.
- Twelve sets of chrome plated wire universal angles accommodate a large variety of pan sizes on adjustable 1-1/2" centers.
- Heavy duty 5" swivel casters, two with brakes. Provides mobility when fully loaded.



H-137-PSUA-12C



ACCESSORIES and OPTIONS (Available at extra cost):

- Tempered Glass Door Windows
- Lock Hasp
- Extra Universal Angles
- Change from standard chrome plated wire angles to angles designed for transporting
- Corner Bumpers
- Perimeter Bumper
- Floor Lock (for use with 5" casters)
- Various Caster Options
- Food Safe Digital Thermometer
- 208 or 240 Volt Service

See page B-20 for accessory details.

H-137-PSUA-12C

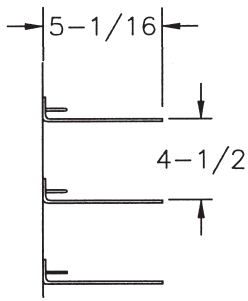

DETAIL OF
PAN SLIDE

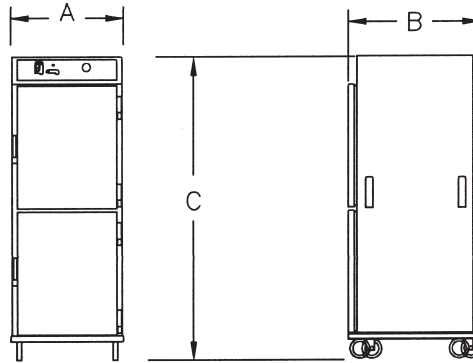
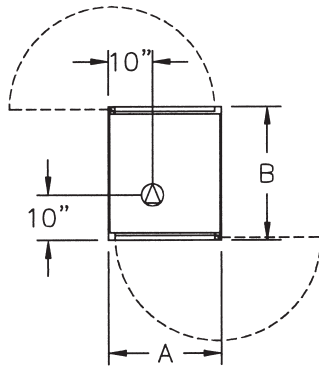

CRES COR MODEL NO.	PAN			DIM "A"	DIM "B"	DIM "C"	INSIDE DIMENSIONS			WEIGHT ACT.	
	CAP ANGLES	SIZE		WIDTH	DEPTH	HEIGHT	WIDTH	DEPTH	HEIGHT		
H-137-PSUA-12C	12 SETS	SEE NOTE BELOW	IN	28-3/4	35	73	21-3/4	27-1/2	58	LBS	313
			MM	730	890	1855	555	700	1475	KG	142

NOTES: 1. Pan sizes 22" x 20" (560 x 510) Roast & Bake Pans, 10" x 20" (255 x 510) Roast & Bake Pans, 18" x 26" (460 x 660) Bun Pans, 14" x 18" (355 x 460) Service Trays, 12" x 20" (305 x 510) Steam Table Pans.
Refer to Pan Size Chart at end of section.

2. When ordering bumpers, add 2" to overall dimensions.

ALL CONSTRUCTION IS RIVETED, WELDED AND FINISHED.

CABINET:

- Body: 22 ga. 304 stainless steel.
- Reinforcement: Internal framework of 18 ga. 304 stainless steel.
- Insulation: Fiberglass, thermal conductivity (K factor) is .23 at 75°F. 1-1/2" in doors, base top; 2" in sidewalls.
- Air tunnels (2): 22 ga. 304 stainless steel; lift-out type, mounted on side walls.
- Push/pull handles (4): 5" vertical; recessed.
- Interior coved corners.

BASE:

- One piece construction, .125 aluminum.
- Casters: 5" dia., swivel, modulus tires, 1-1/4 wide, load cap.
- 250 lbs. each, temp. range -45°/+180°F. Delrin bearings. Front casters equipped with brakes.

DUTCH DOORS:

- Field reversible.
- Formed 22 ga. 304 stainless steel.
- Latches: Chrome plated steel, high temperature ceramic magnetic type, mounted inboard.
- Transport latches
- Hinges: Heavy duty chrome plated steel.
- Gaskets: Perimeter type, silicone.
- Pan stops: Embossed.

PAN SLIDES:

- Wire angles (.306 dia.), nickel chrome plated steel, mounted on lift-off posts.
- Spaced on 4-1/2" centers; adjustable on 1-1/2" centers.

HOT UNIT COMPONENTS:

- Top mounted: removable with tools.
- Thermostat: Mechanical, room ambient to 200°F (93°C).
- Switch: ON-OFF rocker type.
- Power light.
- Power cord: Permanent, 10 ft., 12/3 ga.
- Heaters (2): 1000 Watts each.
- Blower motors (2).
- Vent Fan.
- Thermometer: Analog

POWER REQUIREMENTS:

- 2000 Watts, 120 Volts, 60 Hz., single phase, 16 Amps., 20 Amp. service.

SHORT FORM SPECIFICATIONS

Cres Cor Insulated Pass-Thru Hot Cabinet Model H-137-PSUA-12C. Cabinet 22 ga. 304 stainless steel; stainless steel internal frame. (12) sets wire universal angles for multiple pan sizes, adjustable spacing every 1-1/2". Field reversible Dutch doors, 22 ga. 304 stainless steel. Fiberglass insulation in sides, 2"; doors, base, top 1-1/2". Interior coved corners. Hose out cleaning capability. 2000 Watt, 120 Volt power unit. One piece insulated base, .125 aluminum. 5" swivel modulus casters, Delrin bearings. Load capacity 250 lbs. each. 2 year parts warranty. Provide the following accessories: _____ . NSF, CSA-US, CSA-C, Energy Star Qualified.



5925 Heisley Road • Mentor, OH 44060-1833
Phone: 877/CRESCOR • Fax: 440/350-7267
www.crescor.com

© Crescent Metal Products, Inc. 2008 All rights reserved.

In line with its policy to continually improve its products, CRES COR reserves the right to change materials and specifications without notice.

Litho in U.S.A.