

AQUATEMP™/ROAST-N-HOLD™ UNDERCOUNTER CONVECTION OVEN MODEL CO-151-XW-UA-5B

FEATURES AND BENEFITS:

- Roast, cook, bake, reheat and hold with precise temperature and humidity control. Slow convected air system promotes natural browning for flavor and seals in natural juices.
- Moist heat, dry heat or a combination of both allows for a variety of food preparation and holding.
- Full 1920 Watts of power allows for reheating of prepared meals or bulk items. Maximum temperature 350°F. (176.5°C.).
- 925 Watt water heater with separate control and low water indicator.
- Energy Management Logic system electronically directs power to where it's needed most during different operating cycles.
- Pre-setting automatic controls for roasting and holding cycles allows for unattended operation 24 hours a day.
- Roast and hold over 100 lbs. (45.4 kg.) of meat in just 6 sq. ft. of floor space. Convenient undercounter height makes the most of valuable kitchen space.
- Non-venting oven, permitted by most local codes, provides easy, inexpensive installation.
- Stainless steel construction throughout for ease of cleaning.
- Smooth interior coved corners prevent food particle/grease buildup.
- Field reversible insulated door prevents temperature loss. Silicone door gasket for proper seal. High temperature ceramic magnetic latch for "easy open" and security during transport.
- Safety conscious anti-microbial latch protects against spreading germs. Standard with right hand hinging; left hand hinging available upon request.
- Non-corrosive stainless steel wire universal angles accommodate a large variety of pan sizes on adjustable 1-1/2" spacing. Supplied with five sets of angles and two raised wire grids.
- Heavy duty 2-1/2" swivel casters, two with brakes. Provides mobility when fully loaded.
- Probe Power Unit Available at Extra Cost (see page E-6)



CO-151-XW-UA-5B



ACCESSORIES and OPTIONS (Available at extra cost):

- Security Panel for Controls
- Tempered Glass Door Window
- Key Lock Latch
- Extra Universal Angles
- Extra Wire Grids
- Side and Rear Bumpers
- 4950 Watts, 208 Volt
- 4950 Watts, 240 Volt
- 3 Phase

See page E-10 for accessory details.

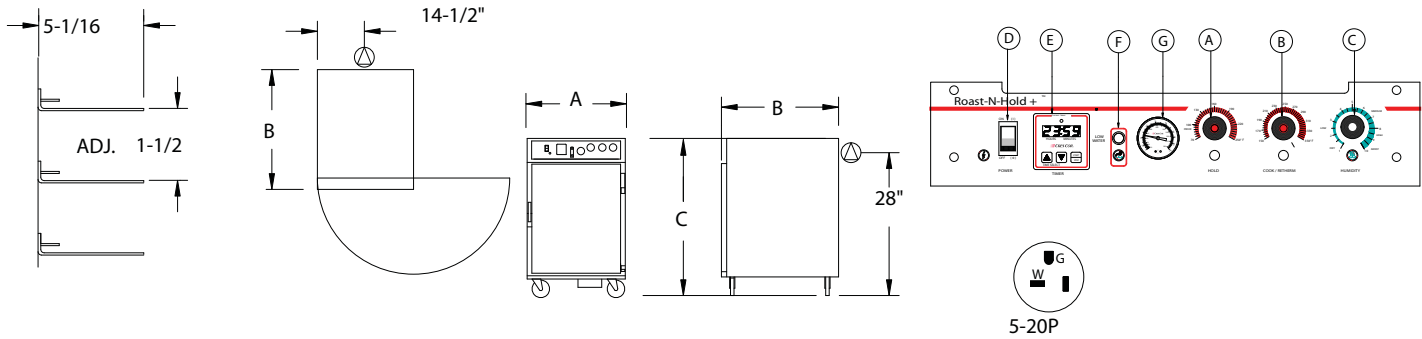

DETAIL OF PAN SLIDE

| CRES COR MODEL NO. | PAN | | | DIM "A" | DIM "B" | DIM "C" | INSIDE DIMENSIONS | | | | WEIGHT ACT. |
|--------------------|------------|----------------|----|---------|---------|---------|-------------------|--------|--------|-----|-------------|
| | CAP/ANGLES | SIZE | | WIDTH | DEPTH | HEIGHT | WIDTH | DEPTH | HEIGHT | | |
| CO-151-XW-UA-5B | 5 SETS | SEE NOTE BELOW | IN | 28 | 35-3/4 | 32 | 21-1/4 | 26-1/2 | 20 | LBS | 200 |
| | | | MM | 715 | 910 | 815 | 540 | 675 | 510 | KG | 91 |

Note: Refer to pan size chart at end of section.
ALL CONSTRUCTION IS RIVETED, WELDED AND FINISHED.

CABINET:

- Body: 22 ga. stainless steel.
- Reinforcement: Internal framework of 16 ga. stainless steel.
- Insulation: Fiberglass, thermal conductivity (K factor) is .23 at 75°F. 1-1/2" in back wall, door, base; 2" in side walls.
- Water pan: 4 Gallons; 16 ga. stainless steel with 925 Watt heater and with petcock drain; mounted to base.
- Drip trough: Formed 18 ga. stainless steel; mounted to lower front of cabinet; removable drip pan.
- Air tunnel: 20 ga. stainless steel, lift-out type, mounted on rear wall.

BASE:

- One piece construction, .125 aluminum.
- Casters: 2-1/2" dia., swivel, polyolefin tires, 1-1/8 wide, load cap. 150 lbs. each, temp. range -40°/+180°F. Plain bearings. Front casters equipped with brakes.

DOOR:

- Field reversible.
- Formed 22 ga. stainless steel.
- Latch: Anti-microbial chrome plated zinc with composite handle, ceramic magnetic type; mounted inboard.
- Hinges: Heavy duty chrome plated zinc, mounted inboard.
- Gasket: Perimeter type, silicone.
- Pan stop: Embossed.

PAN SLIDES:

- Stainless steel wire universal angles (.306 dia.) mounted on lift-out posts.
- (5) sets of angles adjustable on 1-1/2" centers.
- Grids (2): Nickel chrome plated steel, raised wire 17" x 25".

POWER REQUIREMENTS AVAILABLE:

- 1920 Watts, 120 Volts, 60 Hz., 1 phase, 16 Amps., 20 Amp. service.

POWER UNIT COMPONENTS: (refer to above drawing)

- Body: Formed 20 ga. stainless steel with black control panel, recessed.
- A) Thermostat (holding): Solid state, 140°F. (60°C.) to 250°F. (121°C.).
- B) Thermostat (cook/retherm): Solid state, 140°F. (60°C.) to 350°F. (176.5°C.).
- C) Thermostat (humidity): Solid state.
- D) Switch: Lighted ON-OFF rocker type.
- E) Timer: 24 hr. digital countdown; infinite memory retention.
- F) Pilot light for low water level.
- G) Thermometer.
- Power cord: Permanent, 8 ft., 12/3 ga. with right angle plug.
- Air heater: 1920 Watts.
- Water heater: 925 Watts.
- Blower motors (2).
- Vent fans (2).

INSTALLATION REQUIREMENTS:

- Check local vent hood codes for mobile Roast-N-Hold ovens.

| SHORT FORM SPECIFICATIONS |
|--|
| <p>Cres Cor AquaTemp Roast-N-Hold Under Counter Convection Oven Model CO-151-XW-UA-5B. Removable power unit 20 ga. stainless steel, recessed control panel. Cabinet 22 ga. stainless steel. Stainless steel internal frame; coved corner interior. 16 ga. stainless steel water reservoir, 4 gallon capacity. Fiberglass insulation in sides 2"; back, door and base 1-1/2". 22 ga. stainless steel door, high temperature anti-microbial magnetic latch, heavy duty hinges. (5) sets universal angles for multiple pan sizes and spacing. One piece base .125 aluminum. 2-1/2" swivel polyolefin casters. Load capacity 150 lbs. each. 1920 Watts, 120 Volts, 60 Hz., 1 Phase. 2 year parts warranty. Provide the following accessories: _____ . CSA-US, CSA-C, CSA to NSF4 listed.</p> |



5925 Heisley Road • Mentor, OH 44060-1833
Phone: 877/CRESCOR • Fax: 440/350-7267
www.crescor.com

© Crescent Metal Products, Inc. 2008 All rights reserved.

In line with its policy to continually improve its products, CRES COR reserves the right to change materials and specifications without notice.