

PASS-THRU AQUATEMP™ ROAST-N-HOLD™ GENTLE CONVECTION OVEN MODEL CO-151-FPW-UA-12B-Q1

FEATURES AND BENEFITS:

- Roast, cook, bake, reheat and hold with precise temperature and humidity control. Supplied with food probes to constantly monitor and control internal food temperature throughout the cooking and holding stages.
- Slow convected air system promotes natural browning for flavor and seals in natural juices.
- Moist heat, dry heat or a combination of both allows for a variety of food preparation and holding.
- Full 8200 Watts of power allows for reheating of prepared meals or bulk items. Maximum temperature 350°F. (176.5°C.).
- 1850 Watt water heater with separate control and low water indicator.
- Energy Management Logic system electronically directs power to where it's needed most during different operating cycles.
- Pre-setting automatic controls for roasting and holding cycles allows for unattended operation 24 hours a day.
- Roast and hold over 300 lbs. (136 kg.) of meat in just 7 sq. ft. of floor space.
- Non-venting oven, permitted by most local codes, provides easy, inexpensive installation.
- Stainless steel construction throughout for ease of cleaning.
- Smooth interior coved corners prevent food particle/grease buildup.
- Pass-thru design allows easy access from preparation and serving areas.
- Field reversible insulated Dutch doors prevent temperature loss. Silicone door gaskets for proper seal. High temperature ceramic magnetic latches for "easy open" and security during transport.
- Safety conscious anti-microbial latches protect against spreading germs. Standard with right hand hinging; left hand hinging available upon request.
- Recessed push/pull handles on both sides prevent damage to walls; allows easy maneuvering.
- Non-corrosive stainless steel wire universal angles accommodate a large variety of pan sizes on adjustable 1-1/2" spacing. Supplied with 12 sets of angles and six raised wire grids.
- Heavy duty 5" swivel casters, two with brakes. Provides mobility when fully loaded.

POWER UNIT OPTIONS:

- 8200 Watts, 208 Volts, 1 Phase, 60 Hz.
- 8200 Watts, 240 Volts, 1 Phase, 60 Hz.
- 8200 Watts, 208 Volts, 3 Phase, 60 Hz.
- 8200 Watts, 240 Volts, 3 Phase, 60 Hz.



CO-151-FPW-UA-12B-Q1

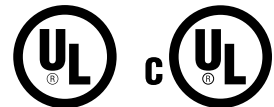

ACCESSORIES and OPTIONS (Available at extra cost):

- Automatic Analog Controls
- Security Panel for Controls
- Tempered Glass Door Windows
- Key Lock Latches
- Extra Wire Grids
- Extra Universal Angles
- Side Bumpers
- Set of 5 preset menu item switches (up to 10 presets allowed)

See page E-10 for accessory details.

CO-151-FPW-UA-12B-Q1

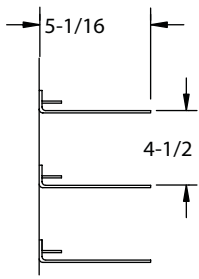

DETAIL OF
PAN SLIDE

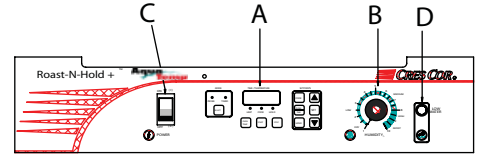
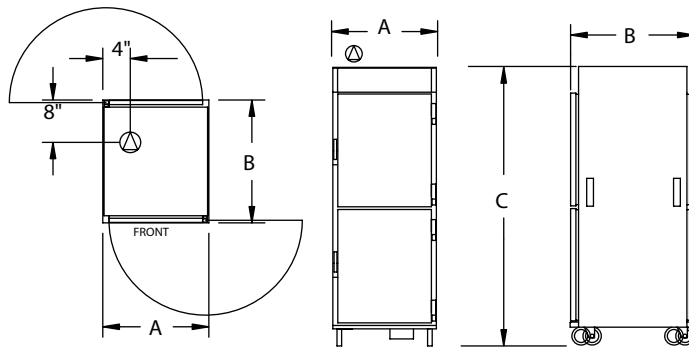

CRES COR MODEL NO.	PAN			DIM "A"	DIM "B"	DIM "C"	INSIDE DIMENSIONS				WEIGHT ACT.
	CAP/ANGLES	SIZE		WIDTH	DEPTH	HEIGHT	WIDTH	DEPTH	HEIGHT		
CO-151-FPW-UA-12B-Q1	12 SETS	SEE NOTE BELOW	IN	28-3/4	37-3/4	73-1/2	21-1/4	26-1/2	58	LBS	470
			MM	730	960	1870	540	675	1475	KG	213

NOTE: Refer to Pan Size Chart at end of section.
ALL CONSTRUCTION IS RIVETED, WELDED AND FINISHED.

CABINET:

- Body: 22 ga. stainless steel.
- Reinforcement: Internal framework of 16 ga. stainless steel.
- Insulation: Fiberglass, thermal conductivity (K factor) is .23 at 75°F. 1-1/2" in back wall, doors, base; 2" in side walls.
- Water pan: 4 Gallons; 16 ga. stainless steel with 1850 Watt heater and with petcock drain; mounted to base.
- Drip trough: Formed 18 ga. stainless steel; mounted to lower front and rear of cabinet; removable drip pan.
- Air tunnels (2): 20 ga. stainless steel, lift-out type, mounted on side walls.
- Push/pull handles (4): 7" vertical; recessed.

BASE:

- One piece construction, .125 aluminum.
- Casters: 5" dia., swivel, modulus tires, 1-1/4 wide, load cap. 250 lbs. each, temp. range -45°/+180°F. Delrin bearings. Front casters equipped with brakes.

DUTCH DOORS:

- Field reversible.
- Formed 22 ga. stainless steel.
- Latches: Anti-microbial chrome plated zinc with composite handle, ceramic magnetic type; mounted inboard.
- Hinges: Heavy duty chrome plated zinc, mounted inboard.
- Gaskets: Perimeter type, silicone.
- Pan stops: Embossed.

PAN SLIDES:

- Stainless steel wire universal angles (.306 dia.); mounted on lift-out posts.
- 12 sets of angles adjustable on 1-1/2" centers.
- Grids (6): Nickel chrome plated steel, raised wire 17" x 25".

POWER REQUIREMENTS AVAILABLE:

- 8200 Watts, 208 Volts, 60 Hz., 1 phase, 39 Amps., 50 Amp. service.
- 8200 Watts, 240 Volts, 60 Hz., 1 phase, 34 Amps., 50 Amp. service.
- 8200 Watts, 208 Volts, 60 Hz., 3 phase, 23 Amps., 30 Amp. service.
- 8200 Watts, 240 Volts, 60 Hz., 3 phase, 20 Amps., 30 Amp. service

POWER UNIT COMPONENTS: (refer to above drawing)

- Body: Formed 20 ga. stainless steel with black control panel, recessed and tilted 7°.
- A) Thermostat (microprocessor)
 - Holding up to 250° F. (121° C.)
 - Cook/Retherm up to 350° F. (176° C.)
 - Thermometer
- B) Thermostat (humidity): Solid state.
- C) Switch: Lighted ON-OFF rocker type.
- D) Pilot light for low water level.
- Power cord: Permanent, 8 ft., 6/3 ga. with right angle plug.
- Air heaters (3): 2670 Watts each.
- Water heater: 1850 Watts.
- Blower motors (3).
- Vent fans (2).
- Fuses (2): 3 Amp.
- Probes (2): 1-1/2" and 6", stainless steel.

INSTALLATION REQUIREMENTS:

- Check local vent hood codes for mobile Roast-N-Hold ovens.

SHORT FORM SPECIFICATIONS

Cres Cor Pass-Thru AquaTemp Roast-N-Hold Convection Oven Model CO-151-FPW-UA-12B-Q1. Removable power unit 20 ga. stainless steel, recessed control panel. Two stainless steel probes, 1-1/2" and 6" long. Cabinet 22 ga. stainless steel. Stainless steel internal frame; coved corner interior. Dutch doors front and back, 22 ga. stainless steel, high temperature anti-microbial magnetic latches, heavy duty hinges. 16 ga. stainless steel water reservoir, 4 gallon capacity. Fiberglass insulation in sides 2"; back, doors and base 1-1/2". (12) sets universal angles for multiple pan sizes and spacing. One piece base .125 aluminum. 5" swivel modulus casters, Delrin bearings. Load capacity 250 lbs. each. 8200 Watts, _____ Volts, 60 Hz., _____ Phase. 2 year parts warranty. Provide the following accessories: _____ . UL, CUL, UL Sanitation listed.



5925 Heisley Road • Mentor, OH 44060-1833
Phone: 877/CRESCOR • Fax: 440/350-7267
www.crescor.com

© Crescent Metal Products, Inc. 2008 All rights reserved.

In line with its policy to continually improve its products, CRES COR reserves the right to change materials and specifications without notice.

Litho in U.S.A.