

SUPER SIZE DISH DOLLY MODEL 501-13-180

FEATURES AND BENEFITS:

- Holds 11-1/2" to 13" plates and platters for transport and storage.
- Fits conveniently under standard 36" counter (height 32").
- Protective plastic coating at points of contact with dishware, prevents chipping.
- Base constructed of one piece, non-corrosive, Hi-Tensile aluminum with cross brace reinforcement for added strength.
- Special wide track caster placement assures stability.
- Heavy duty 5" swivel casters, two with brakes. Provides mobility when fully loaded. No rust sealed bearings prevent "wheel lock" in wet environments.



501-13-180



ACCESSORIES and OPTIONS (Available at extra cost):

- Vinyl Dust Cover
- Perimeter Bumper
- Corner Bumpers
- Various Caster Options

See page H-9 for accessory details.

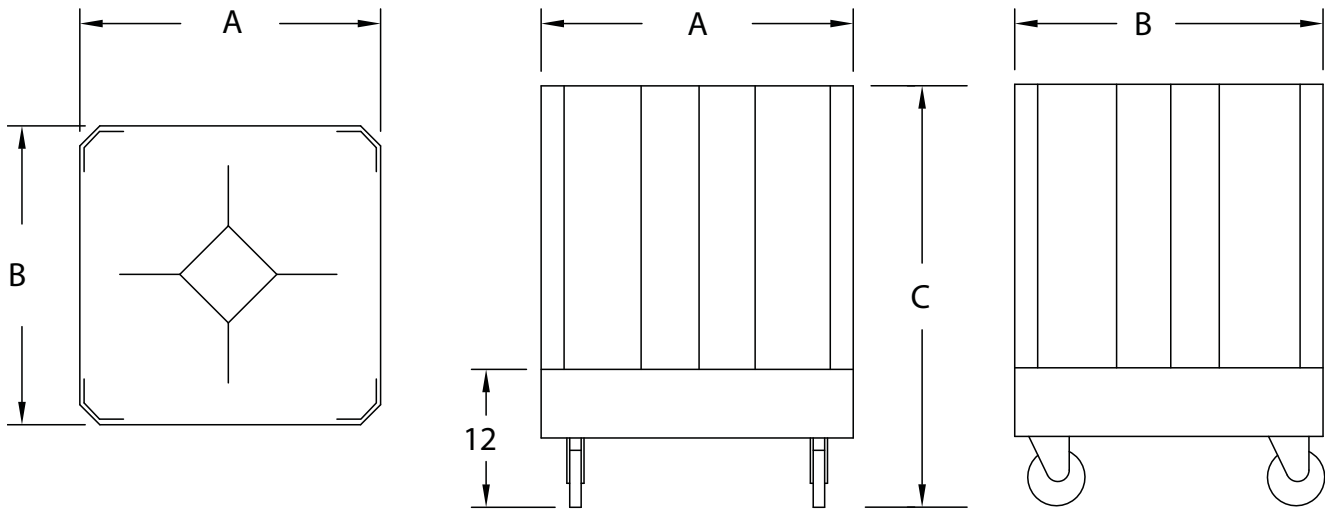

CRES COR MODEL NO.	*PLATE CAP.	DISH SIZE DIA.		DIM "A" WIDTH		DIM "B" DEPTH		DIM "C" HEIGHT		WEIGHT ACT.	
		INCHES	MM	INCHES	MM	INCHES	MM	INCHES	MM	LBS	KG
501-13-180	180	11-1/2 - 13	295 - 330	27-1/8	690	27-1/8	690	32	815	60	27

*Capacity shown is approximate; each compartment holds 20" (510 mm) stack of dishes

ALL ALUMINUM CONSTRUCTION.

DOLLY:

- Base and center partition: .100 aluminum.
- Center partition cover: .063 aluminum.
- Reinforcement: Formed .190 "X-frame" mounted to base.
- Corner posts and dividers: Plastic coated, extruded channels.
- Caster posts: Reinforced tubular extrusions.
- Casters: 5" dia., swivel, modulus tires, 1-1/4 wide, load cap. 250 lbs. each, temp. range -45°/+180°F. Delrin bearings. Two casters equipped with brakes.

SHORT FORM SPECIFICATIONS

Cres Cor Super Size Dish Dolly Model 501-13-180 with base and center post of .100 aluminum. Base reinforced with .190 aluminum "X" bracing. Plastic coated corner posts and dividers. Capacity of 180 plates 11-1/2" to 13" dia. Five inch swivel modulus casters have Delrin bearings. Load capacity 250 lbs. each. 2 year parts warranty. Provide the following accessories: _____ . NSF listed.



5925 Heisley Road • Mentor, OH 44060-1833
 Phone: 877/CRESCOR • Fax: 440/350-7267
 www.crescor.com

© Crescent Metal Products, Inc. 2008 All rights reserved.

In line with its policy to continually improve its products, CRES COR reserves the right to change materials and specifications without notice.

Litho in U.S.A.