

## NON-INSULATED HOT CABINETS 131-UA SERIES

### FEATURES AND BENEFITS:

- Non-Insulated hot cabinet to keep prepared foods at serving temperatures.
- Powerful, yet efficient, heating system maintains the right temperature to properly hold products. 1920 Watt heater holds foods at up to 180°F (82°C).
- Body constructed of non-corrosive, Hi-Tensile aluminum with extruded frame fully welded for strength and ease of mobility.
- Perimeter door gasket minimizes heat loss.
- Reinforced, field reversible brushed aluminum door for flexibility. Standard with right hand hinging; left hand hinging available upon request.
- Safety-conscious anti-microbial latch protect against spreading germs.
- Magnetic type latch secures door during transport.
- Wire universal angles accommodate a large variety of pan sizes on adjustable 1-1/2" centers.
- Controls accessible without opening door; allows adjustments without interrupting process.
- Slanted control panel has easy-to-read thermometer; entire assembly removable for cleaning and maintenance.
- Heavy duty 5" swivel casters, two with brakes. Provides mobility when fully loaded.



131-UA-11D  
(Shown with optional Lexan door)

SANITATION  
CLASSIFIED



CLASSIFIED TO  
NSF4



### ACCESSORIES and OPTIONS (Available at extra cost):

- Lock Hasp
- Lexan Door
- Extra Universal Angles
- Dutch Doors
- Corner Bumpers
- Perimeter Bumper (three sided)
- Floor Lock (for use with 5" casters)
- Push Handle
- Various Caster Options
- Digital Thermometer
- 208 or 240 Volt Service

See page B-20 for accessory details.

# 131-UA Series

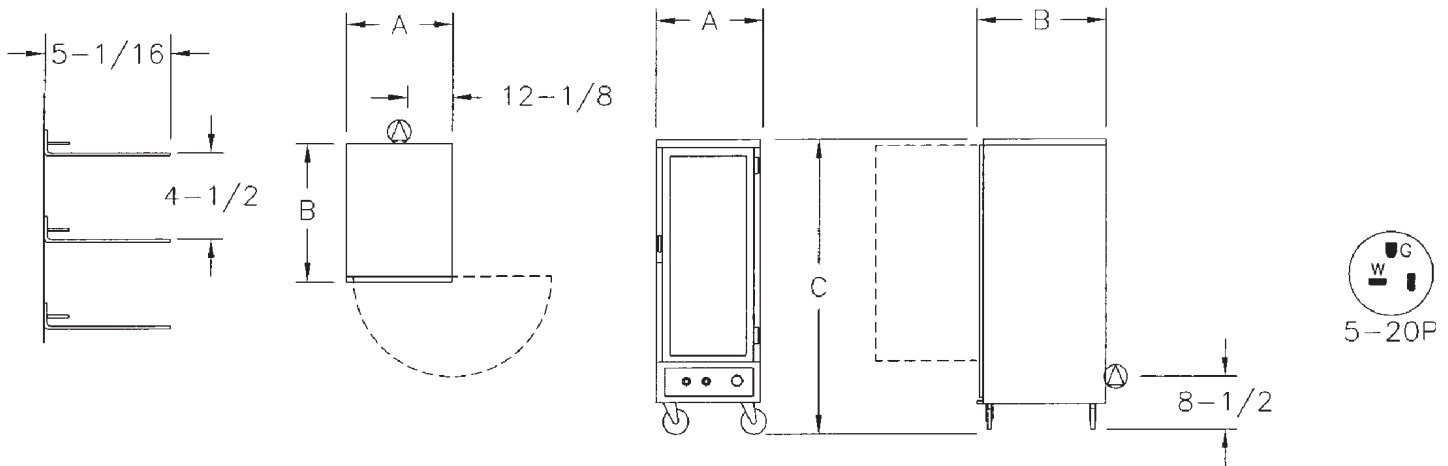

CRES COR MODEL NO.	PAN			DIM "A"	DIM "B"	DIM "C"	INSIDE DIMENSIONS			WEIGHT ACT.	
	CAP/ ANGLES	SIZE		WIDTH	DEPTH	HEIGHT	WIDTH	DEPTH	HEIGHT		
131-UA-9D	9 SETS	SEE NOTE BELOW	IN	24-1/4	32	57-3/4	21-1/4	28-1/4	42-3/8	LBS	173
			MM	620	815	1470	540	718	1080	KG	78
131-UA-11D	11 SETS	SEE NOTE BELOW	IN	24-1/4	32	69-3/4	21-1/4	28-1/4	54-3/8	LBS	198
			MM	620	815	1775	540	718	1385	KG	90

NOTES: 1. Pan sizes 22" x 20" (560 x 510) Roast & Bake Pans, 10" x 20" (255 x 510) Roast & Bake Pans, 18" x 26" (460 x 660) Bun Pans, 14" x 18" (355 x 460) Service Trays, 12" x 20" (305 x 510) Steam Table Pans. Refer to Pan Size Chart at end of section.  
 2. When ordering bumpers, add 2" to overall dimensions.

ALL ALUMINUM CONSTRUCTION IS RIVETED, WELDED AND FINISHED.

## CABINET:

- Top: One piece .063 aluminum; riveted to sides and back.
- Side panels: Formed .063 aluminum; fastened to base and top.
- Back: .063 aluminum; fastened to base and top.
- Air tunnel: .063 aluminum; lift-out type, mounted to the back panel.

## BASE:

- One piece construction, .125 aluminum.
- Casters: 5" dia., swivel, modulus tires, 1-1/4 wide, load cap. 250 lbs. each, temp. range -45°/+180°F. Delrin bearings. Front casters equipped with brakes.

## DOOR:

- Field reversible.
- Panel: .063 brushed aluminum, fitted into door frame extrusions, 13/16 x 1-11/16 x .154; Black powder coated.
- Latch: Chrome plated steel, magnetic type; mounted inboard
- Hinges (2): Chrome plated steel.
- Gasket: Perimeter type, Santoprene rubber.

## PAN SLIDES:

- Wire angles, (.306 dia.) nickel chrome plated steel, mounted on lift-out posts.
- Spaced on 4-1/2" centers; adjustable on 1-1/2" centers.

## HOT UNIT COMPONENTS:

- Removable bottom mount hot unit.
- Body: Formed .063 aluminum with black control panel.

## HOT UNIT COMPONENTS (CONT.):

- Thermostat: Mechanical, room ambient to 180°F (82°C).
- Switch: ON-OFF rocker type.
- Power light
- Power cord: Permanent, 6 ft., 12/3 ga. with molded plug.
- Heater: 1920 Watts.
- Blower motor.
- Thermometer.

## POWER REQUIREMENTS:

- 1920 Watts, 120 Volts, 60 Hz., single phase, 16 Amps., 20 Amp. service.

## SHORT FORM SPECIFICATIONS

Cres Cor Hot Cabinet Model 131-UA-\_\_\_D. Formed and welded .063 aluminum top, .125 aluminum base. (\_\_\_) sets extruded universal angles for multiple pan sizes, adjustable spacing every 1-1/2". Brushed .063 aluminum door. Removable 1920 Watt, 120 Volt power unit. Controls accessible without opening door. 5" swivel modulus casters, Delrin bearings. Load capacity 250 lbs. each. 2 year parts warranty. Provide the following accessories: \_\_\_ \_\_\_ \_\_\_ . UL Sanitation, CUL, UL listed.



5925 Heisley Road • Mentor, OH 44060-1833  
 Phone: 877/CRESCOR • Fax: 440/350-7267  
 www.crescor.com

© Crescent Metal Products, Inc. 2006 All rights reserved.

*In line with its policy to continually improve its products, CRES COR reserves the right to change materials and specifications without notice.*

Litho in U.S.A.