

NON-INSULATED TRANSPORT STORAGE CABINET MODEL 101-1820D

FEATURES AND BENEFITS:

- Non-insulated all purpose cabinet for transport and storage.
- Same size top and base extend past sidewalls to act as natural bumpers for protection. Extruded frame fully welded.
- Body constructed of non-corrosive, Hi-Tensile aluminum for strength and ease of mobility.
- Reinforced, full length door swings 270° and can be latched to the cabinet side for convenience. Card clip included.
- Gravity type latch secures door during transport.
- Extruded angle ledge pan supports hold 18" x 26" pans or 14" x 18" trays on 3" centers.
- Interior pan stops on door and back allow proper air flow.
- Heavy duty 5" swivel casters, two with brakes. Provides mobility when fully loaded.



101-1820D



ACCESSORIES and OPTIONS

(Available at extra cost):

- Lock Hasp
- Various Caster Options
- Corner Bumpers
- Perimeter Bumper
- Floor Lock (for use with 5" casters)
- Plexiglas Door
- Push Handle
- Bail Handle Kit
- Left-Hand Hinged Door
- Kold Keepers

See page A-20 for accessory details.

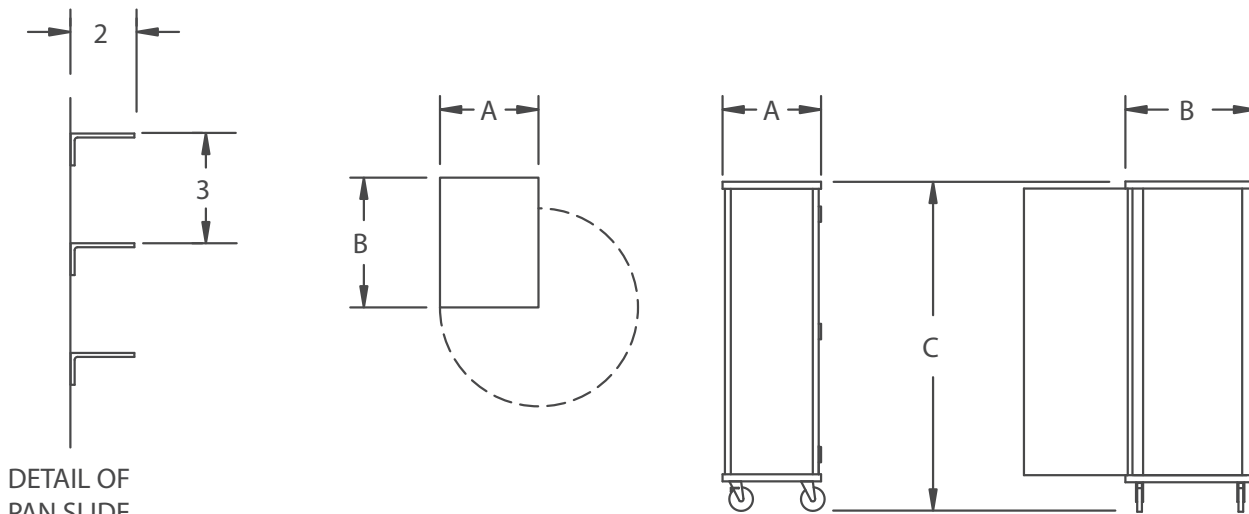

CRES COR MODEL NO.	PAN			DIM "A" WIDTH	DIM "B" DEPTH	DIM "C" HEIGHT	INSIDE DIMENSIONS			WEIGHT ACT.	
	CAP	SIZE					WIDTH	DEPTH	HEIGHT		
101-1820D	20	18 x 26	IN	21	31	69-3/4	18-3/16	28-1/2	61-1/2	LBS	155
		460 x 660	MM	535	790	1775	465	725	1565	KG	70
	40	14 x 18	IN								
		360 x 460	MM								

When ordering bumpers, add 2" to overall dimensions.
 ALL ALUMINUM CONSTRUCTION IS RIVETED, WELDED AND FINISHED.

CABINET:

- Posts: Extruded channels, 7/8 x 2-1/4 x .102, welded to top and base, form a solid frame.
- Sides and back: .063 panels riveted to posts.
- Back panel: Fitted into posts, riveted to top and reinforced.
- Tie rod: Applied at front.
- Top: One piece .100 aluminum.
- Pan stop channels: Mounted to inside rear of cabinet and door.

PAN SLIDES:

- Extruded angle supports 1 x 2 x .125 riveted to sides on 3" centers.

BASE:

- One piece construction, .190 aluminum.
- Casters: 5" dia., swivel, modulus tires, 1-1/4 wide, load cap. 250 lbs. each, temp. range -45°/+180°F. Delrin bearings. Front casters equipped with brakes.

DOOR:

- Panel: Formed .100 aluminum.
- Reinforcement: 1/4 x 1-1/2 extruded bars riveted horizontally to top, center and bottom.
- Latch: Gravity type, nickel plated steel.
- Swings 270° on 3 butt hinges, riveted to posts and door.

SHORT FORM SPECIFICATIONS

Cres Cor Utility Cabinet Model 101-1820D. Formed and welded .100 aluminum top, .190 aluminum base. Extruded aluminum angles riveted on 3" centers. Formed .100 aluminum reinforced door. 5" swivel modulus casters, Delrin bearings. Load capacity 250 lbs. each. Provide the following accessories: _____
 _____ . NSF listed. 2 year parts warranty.