

COOK-N-HOLD LOW TEMPERATURE RADIANT OVEN MODEL 1000-CH-SS-SPLIT SERIES

FEATURES AND BENEFITS:

- Fully insulated Cook-N-Hold gentle radiant oven designed for flavorful results by slow cooking.
- Slow cooking means 15% to 20% less shrinkage.
- Efficient 3000 Watt power unit allows for reheating of prepared meals or bulk items. Maximum temperature 325° (163°C). Easy to read thermometer.
- Pre-setting automatic controls for cooking and holding cycles allows for unattended operation.
- Cook and hold over 120 lbs. (54 kg.) of meat in just 5 sq. ft. of floor space.
- Non-venting oven, permitted by most local codes, provides easy, inexpensive installation.
- Fully insulated, stainless steel interior and exterior for ease of cleaning.
- Oven is operable on either 208 or 240 Volt circuits at the flip of a switch.
- Smooth interior coved corners prevent food particle/grease buildup.
- Field reversible insulated door prevents temperature loss. Silicone door gasket for proper seal. High temperature ceramic magnetic latch for "easy open" and security during transport.
- Safety conscious anti-microbial latch protect against spreading germs.
- Standard with right hand hinges; left hand hinging available upon request.
- Stainless steel pan slides hold eight (8) 18" x 26" pans on 3" centers. Supplied with 3 wire grids.
- Heavy duty 5" swivel casters, two with brakes. Provides mobility when fully loaded.
- Ovens can be stacked for flexibility.

POWER UNIT OPTIONS:

3000 Watts, 208/240 Volts, 1 Phase, 60 Hz.

3000 Watts, 208/240 Volts, 3 Phase, 60 Hz.



7 Year Limited Warranty
On all Cook-N-Hold heating elements (Excludes Labor).



1000-CH-SS-SPLIT



SANITATION
NSF/ANSI 4



C US

ACCESSORIES and OPTIONS (Available at extra cost):

- Tempered Glass Door Window
- Key Lock Latch
- Extra Wire Grids
- Perimeter Bumper
- Corner Bumpers
- Floor Lock (for use with 5" casters)
- Various Caster Options
- Cord Installation

See page E-10 for accessory details.

1000-CH-SS-SPLIT SERIES

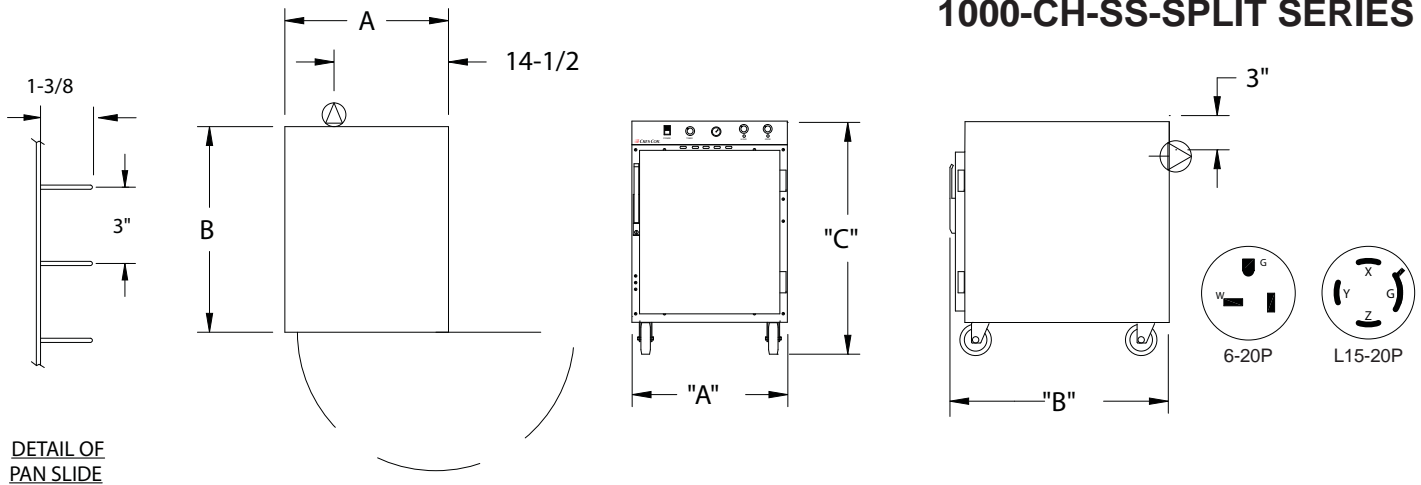

DETAIL OF PAN SLIDE

CRES COR MODEL NO.	PAN			DIM "A"	DIM "B"	DIM "C"	INSIDE DIMENSIONS*				WEIGHT ACT.
	CAP	SIZE		WIDTH	DEPTH	HEIGHT	WIDTH	DEPTH	HEIGHT		
1000-CH-SS-SPLIT	8	18 X 26	IN	22-5/8	32-3/4	42	18-3/16	27	26-3/4	LBS	215
		460 X 660	MM	575	835	1070	465	690	680	KG	98
1000-CH-SS-SPLIT (Stacked)	16	18 X 26	IN	22-5/8	32-3/4	77	18-3/16	27	26-3/4	LBS	430
		460 X 660	MM	575	835	1960	465	690	680	KG	195

*Inside dimensions for each compartment

CABINET:

- Body: 22 ga. stainless steel outer body.
- Inner body & top: 18 ga. stainless steel.
- Reinforcement: Internal framework of 18 ga. stainless steel.
- Insulation: Fiberglass, thermal conductivity (K factor) is .23 at 75°F, 1-1/2" in walls, 1" in doors.
- Drip pan: 18 ga. stainless steel with drain.
- Casters: 5" dia., swivel, modulus tires, 1-1/4 wide, load cap. 250 lbs. each, temp. range -45°/+180°F. Delrin bearings. Front casters equipped with brakes.

DOOR:

- Field reversible.
- Formed 20 ga. stainless steel.
- Latch: Anti-microbial chrome plated zinc with composite handle, ceramic magnetic type; mounted inboard.
- Hinges (2): Heavy duty chrome plated zinc; mounted inboard
- Gaskets: Perimeter type, silicone.

PAN SLIDES:

- 18 ga. stainless steel angles, 1 x 1-3/8; riveted on 3" centers.
- Grids: Stainless steel, 18 x 26; supplied with (3) grids.

CLEARANCE REQUIREMENTS:

- 3" (76mm) at the back, 2" (51mm) at the top, 1" (25mm) at both sides.

POWER REQUIREMENTS:

- 3000 Watts, 208/240 Volts, 60 Hz., 1 phase, 20 Amp. Service 14 Amps at 208 Volts, 13 Amps at 240 Volts.
- 3000 Watts, 208/240 Volts, 60 Hz., 3 phase, 20 Amp. Service 8 Amps at 208 Volts, 7 Amps at 240 Volts.

ELECTRICAL COMPARTMENT:

- Control panel: Formed stainless steel; black front.
- Thermostat (HOLD): Electro-mechanical, 140°F (60°C) to 200°F. (93°C.).
- Thermostat (COOK): Electro-mechanical, 140°F (60°C) to 325°F. (163°C).
- Switch: Lighted ON-OFF rocker type.
- Timer: 18 hr.
- Pilot lights.
- Power Cord: Permanent, 6 ft. 12/3 ga. with right angle plug.
- Three (3) heater circuits.
- Thermometer.
- Voltage selector switch: Change to 208 or 240 Volt; on back of oven.

INSTALLATION REQUIREMENTS:

- Check local vent hood codes for mobile Cook-N-Hold ovens.
- Ovens with no cord or plug must be attached to building with a flexible connector. Not factory supplied.

SHORT FORM SPECIFICATIONS

Cres Cor Insulated Radiant Oven Model 1000-CH-SS-SPLIT; Outer body of 22 ga. stainless steel; inner body, top and frame of 18 ga. stainless steel. Fiberglass insulation 1-1/2" in walls; 1" in door. Stainless steel internal frame; coved corners. Anti-microbial chrome plated latch. Thermometer. Three (3) heated inner walls. Removable pan supports for (8) 18" x 26" pans spaced on 3" centers. Casters 5" swivel modulus casters, Delrin bearings. Load capacity 250 lbs. each. 7 year limited warranty. Provide the following accessories: _____
CSA Sanitation & safety certified for US & CAN.



5925 Heisley Road • Mentor, OH 44060-1833
Phone: 877/CRESCOR • Fax: 440/350-7267
www.crescor.com

© Crescent Metal Products, Inc. 2009 All rights reserved.

In line with its policy to continually improve its products, CRES COR reserves the right to change materials and specifications without notice.

Litho in U.S.A.